

Hydrogen Safety: R&D Work in the Horizon Hydrogen Energy Program

S. Ruban, S. Jallais, D. Houssin, V. Naudet, C. Weber, J. Daubech, C. Proust, A. Bengaouer

This document appeared in

Detlef Stolten, Thomas Grube (Eds.):

18th World Hydrogen Energy Conference 2010 - WHEC 2010

Parallel Sessions Book 5: Strategic Analyses / Safety Issues / Existing and Emerging Markets

Proceedings of the WHEC, May 16.-21. 2010, Essen

Schriften des Forschungszentrums Jülich / Energy & Environment, Vol. 78-5

Institute of Energy Research - Fuel Cells (IEF-3)

Forschungszentrum Jülich GmbH, Zentralbibliothek, Verlag, 2010

ISBN: 978-3-89336-655-2

Hydrogen Safety: R&D Work in the Horizon Hydrogen Energie Program

Sidonie Ruban, Simon Jallais, Deborah Houssin, Valérie Naudet, Claire Weber,
Air Liquide, Jouy-en-Josas, France

Jérôme Daubech, Christophe Proust, INERIS, Verneuil-en-Halatte, France

Alain Bengaouer, CEA, Gif-sur-Yvette, France

1 INTRODUCTION

The energy industry is undergoing an important transformation (global warming, dependence of the energy supply, depletion of energetic resources); our societies will have to develop solutions that are sustainable and more environmentally-friendly. In the frame of those global challenges, hydrogen can play a key role in the development of new energy alternatives. As a carrier that is compatible with other types of energies, it can be produced from a wide variety of sources including renewable, while presenting unique storage options and, combined to a fuel cell, efficiently produces electricity with zero direct pollution.

Energy and environment being major growth drivers, Air Liquide decided to lead the Horizon Hydrogène Energie (H2E) program. This ambitious French program represents a global investment of 190 million Euros over 7 years in research and technology development and federates 19 partners in order to implement new industry for hydrogen energy.

Competitive solutions are already available and Air Liquide deploys them onto four main “early” markets – off-grid sites, backup power, special vehicles and mobile energy – with a fully dedicated supply chain as illustrated in Figure 1. In order to establish a market-receptive environment for hydrogen-based products and have development/modification of relevant codes and standards that will ensure the safe operation, handling and use of hydrogen technologies, it is essential to implement a specific safety strategy during the product design phase. A scientific basis for providing realistic risk assessment and possible mitigation means is required to reach the safety objectives.

A comprehensive R&D effort has been launched in the frame of the Horizon Hydrogène Energie (H2E) program for assessing the safety of hydrogen-based systems. It is conducted in collaboration with French research institutes (CEA, INERIS) and French academic laboratories (LCD Poitiers and PRISME Bourges).

As part of the program, investigation on safety aspects covers most areas of hydrogen distribution, storage under high pressure and use in fuel cells. It aims at providing experimental and numerical results to understand hydrogen behaviour in different accident scenarios – from leakage to dispersion, ignition, and explosion – and to understand the behaviour of high pressure full composite hydrogen storage to mechanical and thermal aggressions. Emphasis is given to risk mitigation strategies. The paper presents the work program and introduces methodology and early results.



Figure 1: Overview of hydrogen early markets.

2 Presentation of the Work Program

2.1 Release flow rate and shape in real-leak conditions

The objective of this task consists in experimentally measuring leak rates associated to hydrogen fittings. Knowledge of this value is crucial for risk assessment as it is used as a source term. In risk assessment studies, the leak is generally modelled as a release of gas through a circular hole. However, on the basis of Air Liquide long experience on hydrogen production and distribution technologies, this type of approach to characterize leak is too conceptual and conservative. In the current task, leak flow rates generated by expectable and accidental fitting solicitations will be measured and characterised for two types of commercialized fittings (see Figure 2):

- double ferrule fittings with setting of ferrules and sealing on the conical ferrule (like Swagelok or Sagana fittings),
- and “cone and thread” fittings with thread collar and sealing on a cone (like Sitec or Autoclave fittings).

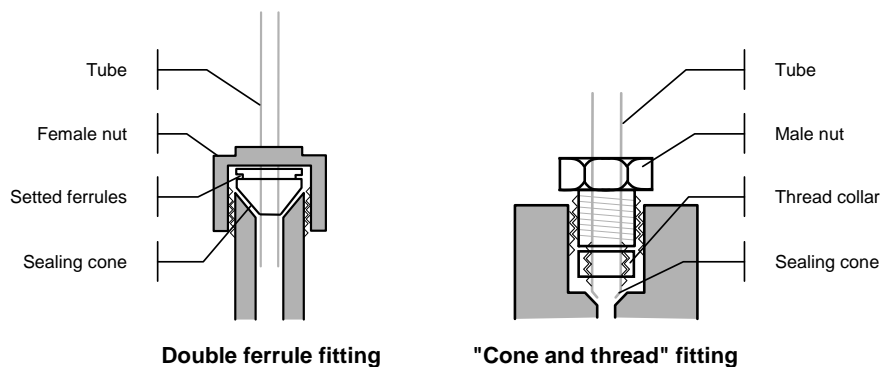

Figure 2: Schemes of the selected fittings.

It should be noticed that these two fitting types are classically used at high pressure (200 bar), even with references at pressures near 1000 bar for “cone and thread” fittings.

A reliability approach was used to determine all causes of leak for a fitting. Fault trees, taking into account the lifetime were built for the two types of fittings. Three main causes were identified: material defaults, assembly faults and solicitations in use. Fault trees also showed that problems due to material and assembly are mainly solved using procedures (double checking for example). Real-life solicitations will be experimentally reproduced in order to quantify their level of leak (see Figure 3).

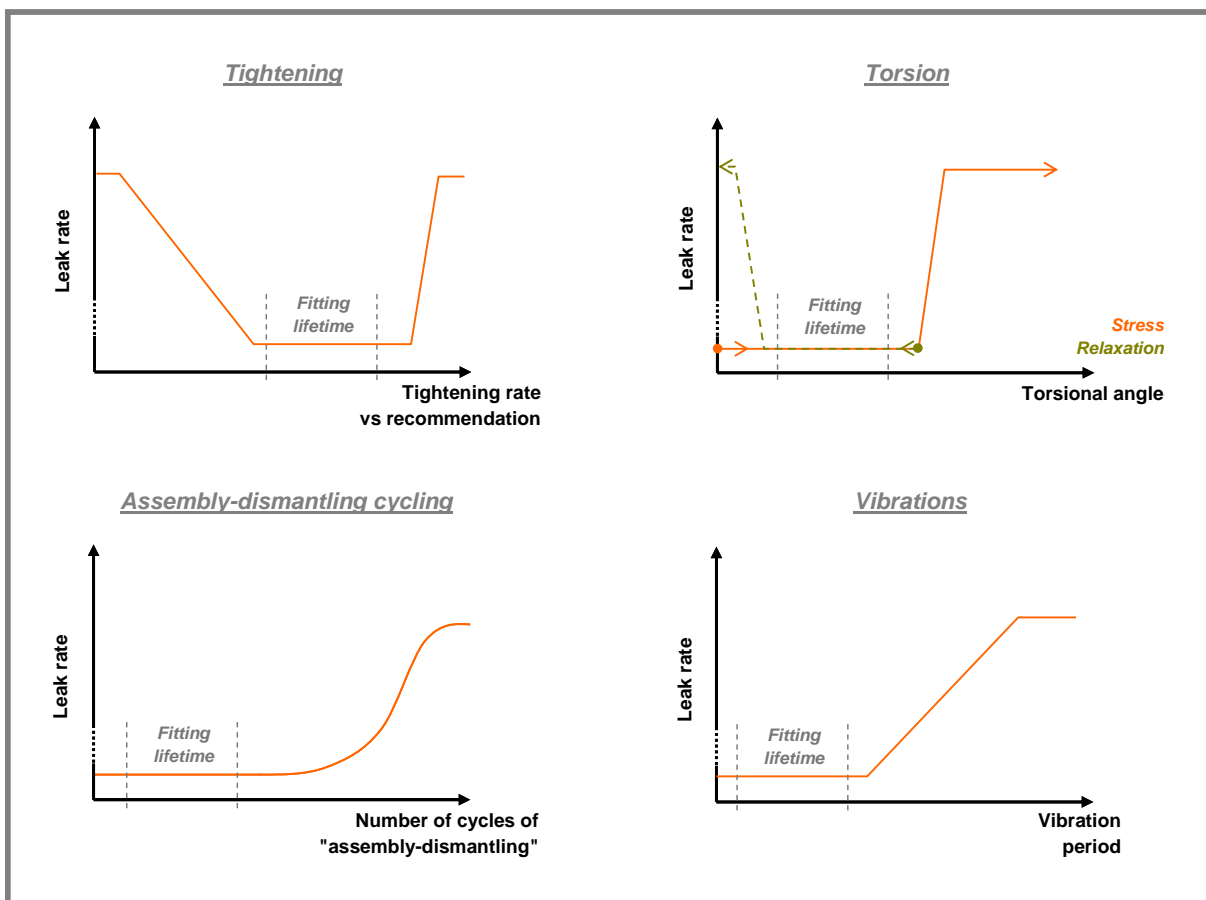

Figure 3: Experimental planned tests.

This type of experiments has been also performed in Drive French national project [1] at moderate pressures (< 35 bar) and for pipe fittings ¼” mainly. It shows that these fittings have a very low leak rate in normal conditions (< 10⁻³ cm³.s⁻¹) but could be an important source of release in case of insufficient tightening or with a default on the fitting (leak rate up to 300 cm³.s⁻¹). Future works in H2E project will extend knowledge on this thematic.

Important outcome of this study will be a better definition of fittings limits of use and of maintenance frequency to ensure an appropriate level of safety. Guidelines for design of the hydrogen-based systems next generation could also be issued.

2.2 Dispersion, gas build-up and deflagration in confined area

In H2E project, a risk informed safety approach is adopted: mitigation objectives are defined with regards to foreseeable deviations or accidental events in function of their expected likelihood:

1. For expectable releases, the objective is to avoid the development of an explosive atmosphere in the considered confined area. This is mainly achieved by ventilation.
2. Less likely accidental releases may have effects, but not to the extent of producing injury (e.g. a flammable mixture may be acceptable if its ignition will produce limited effects).

The task aims to define practical means for meeting these objectives.

Background works have been performed in sealed confined configurations [2,3,4]. Within H2E projects, experiments will be performed in CEA Garage facility (see Figure 4) with a specific focus on natural ventilation (through one or two openings, with and without wind effects) and forced ventilation configurations. Another task is devoted to hydrogen dispersion through a first confinement (which is played by hydrogen objects structure) in a second confinement (i.e. the room where H₂ object is located).



Figure 4: CEA Garage facility (source: CEA).

Experiments on hydrogen-air deflagration (so-called vented explosion) will be performed by INERIS to define design rules of overpressure venting which will have to be a trade-off between internal (overpressure in the confined volume) and external (flame and overpressure outside of the volume) effects. These experiments will also be used to validate CFD combustion codes and to develop engineering predictive tools.

In the project, influence of main parameters characterizing combustion regime, and pressure and thermal loads – mixture composition and mixture distribution (uniform/stratified mixtures); vent size, inertia, opening pressure; degree of obstruction and obstacle(s) configuration – will be investigated both experimentally and numerically.

3 Cylinder Safety

In the hydrogen energy applications, due to global energetic density considerations, hydrogen is stored at high pressure (up to 700 bar) in fully wrapped carbon fibers composite cylinders. These cylinders can undergo thermal and mechanical aggressions.

Thermal aggressions

Thermal aggressions can be generated by a generalized fire, a localized fire (like an impacting jet fire) or an exposure to an excessive temperature (e.g. cylinder in a smoke layer or in a room neighbouring a fire). In order to avoid cylinder burst in the fire, cylinders can be equipped with a TPRD (Thermally activated Pressure Relief Device) [5] releasing hydrogen when its local temperature is excessive considering cylinder materials (typically $T > 110^{\circ}\text{C}$). However, TPRD produce a hazardous hydrogen flame (more than 2 m) and are not an efficient solution in case of local thermal aggression due to their local measuring capacity. As a consequence, H2E program plans to experimentally study specifically designed TPRD leading to short flame (INERIS) and to evaluate protective thermal layer solutions as mitigation strategies (LCD and INERIS).

Some technologies have been identified – e.g. intumescent painting, thermal barrier and wood-based protection – and will be experimentally tested by INERIS in real pool fire configurations for H2E project. Response to heat radiation of the composite, with and without protective layer, will be also studied on the basis of cone calorimeter experiments (LCD).

Mechanical aggressions

Cylinders manipulation in Air Liquide supply chain and during use by the customer can induce exposure to different mechanical aggressions. These aggressions can be mainly a vehicle crash (mobile energy), a vehicle impact (forklift for example) and a drop (e.g. from a delivery truck). Aggression mechanisms characteristics (i.e. velocity, impact energy, impact area, shape of the impinger) which could generate an immediate cylinder failure are unknown. Numerous studies on impact on composite structures have been published since 1990 [6,7]. Unfortunately, very few works are dedicated to impact on cylinder or curved structures. These studies highlighted three damage mechanisms leading to a decrease of the mechanical properties of a composite structure: matrix cracking, fiber rupture and delamination. H2E Safety program will experimentally determine the limits of mechanical aggressions leading to a cylinder burst. On this basis, the need of a mechanical protection on the cylinder will be assessed. These conclusions will be also used to improve Air Liquide technical procedures and recommendations for users and designers.

4 Conclusions

Through H2E program, Air Liquide develops H₂ safety knowledge in order to implement a specific safety strategy and accelerate the development of regulations and standards. This work will contribute to achieve public acceptance of hydrogen energy applications .

References

- [1] O Gentilhomme, I Tkatschenko, G Joncquet, F Anselmet, In: Proceeding of International Conference and Trade Fair on Hydrogen and Fuel Cell technologies, Hamburg, Germany (2008)
- [2] JM Lacomme, Y Dagba, D Jamois, L Perette, C Proust, In: Proceeding of ICHS2, San Sebastian, Spain (2007)
- [3] S Gupta, J Brinster, E Studer, I Tkatschenko – In: Proceeding of ICHS2, San Sebastian, Spain (2007)

- [4] B Cariteau, J Brinster, E Studer, I Tkatschenko, G Joncquet, In: Proceeding of ICHS3, Ajaccio, France, 2009
- [5] Nathan Weyandt, NHTSA, DOT HS 811 150, 46 p. (June 2009)
- [6] SA Matemilola, WJ Stronge, Journal of Pressure Vessel Technology, 119, 435-443 (1997)
- [7] SR Swanson, NL Smith, Y Qian, Composite Structure, 18, 95-108 (1991)