

Definition and Analysis of a Hydrogen Integrated Building in Andalucía, Spain

B. Alzueta, G. García, R. Garde, M. Aguado

This document appeared in

Detlef Stolten, Thomas Grube (Eds.):

18th World Hydrogen Energy Conference 2010 - WHEC 2010

Parallel Sessions Book 6: Stationary Applications / Transportation Applications

Proceedings of the WHEC, May 16.-21. 2010, Essen

Schriften des Forschungszentrums Jülich / Energy & Environment, Vol. 78-6

Institute of Energy Research - Fuel Cells (IEF-3)

Forschungszentrum Jülich GmbH, Zentralbibliothek, Verlag, 2010

ISBN: 978-3-89336-656-9

Definition and Analysis of a Hydrogen Integrated Building in Andalucía, Spain

Beatriz Alzueta, Gabriel García, Raquel Garde, Mónica Aguado, National Renewable Energy Centre (CENER), Ciudad de la Innovación, 7, 31621 Sarriguren, Spain

1 Introduction

If we want to achieve the commitments adopted by the European Commission in order to reduce the CO₂ emissions [1] and to increase the energy produced by renewable sources, it is necessary to make an important effort in all sectors.

Residential sector could contribute to achieve these targets making a more efficient use of the energy and increasing the use of renewable energy.

Hydrogen and fuel cells could be introduced in this sector considering their high efficiency, small size, reliability and general performance.

The owners of households, who are generating electricity for their own needs, could feed surplus electrical power into the grid constituting a small distributed generation system.

If hydrogen is obtained from renewable sources, fuel cells can increase the contribution of renewable sources in the electricity grid and reduce the dependence on fossil fuels.

In this paper, the results obtained in the project carried out by CENER "Definition and analysis of a hydrogen integrated building in Andalucía" are presented. This project has been financed by the Planning and Technology Department of the Consejería de Obras Públicas y Transportes of Andalucía Government, Spain.

Different configurations for this system are analyzed to determine the best option from different points of view: technical, economical and environmental.

2 System Description

CENER has analyzed the feasibility of building a 16 flats building block in Sevilla, Spain, using hydrogen to cover the electrical demands. At the beginning, the aim of the project was to achieve self-sufficiency for the whole building, but due to the high cost of this systems and the space required, this target has been discarded and 4 new configurations have been analyzed using HOMER [2] (Figure 1).

The necessary hydrogen could be produced on site with photovoltaic electricity, purchased to an external gas company, or even reformed from natural gas.

As we can see in Figure 1, in some of those cases the fuel cell is connected to the DC bus, but this does not mean that a DC/AC converter is not necessary. In those cases, both converter costs and the lost of efficiency related are included within the fuel cell cost and efficiency.

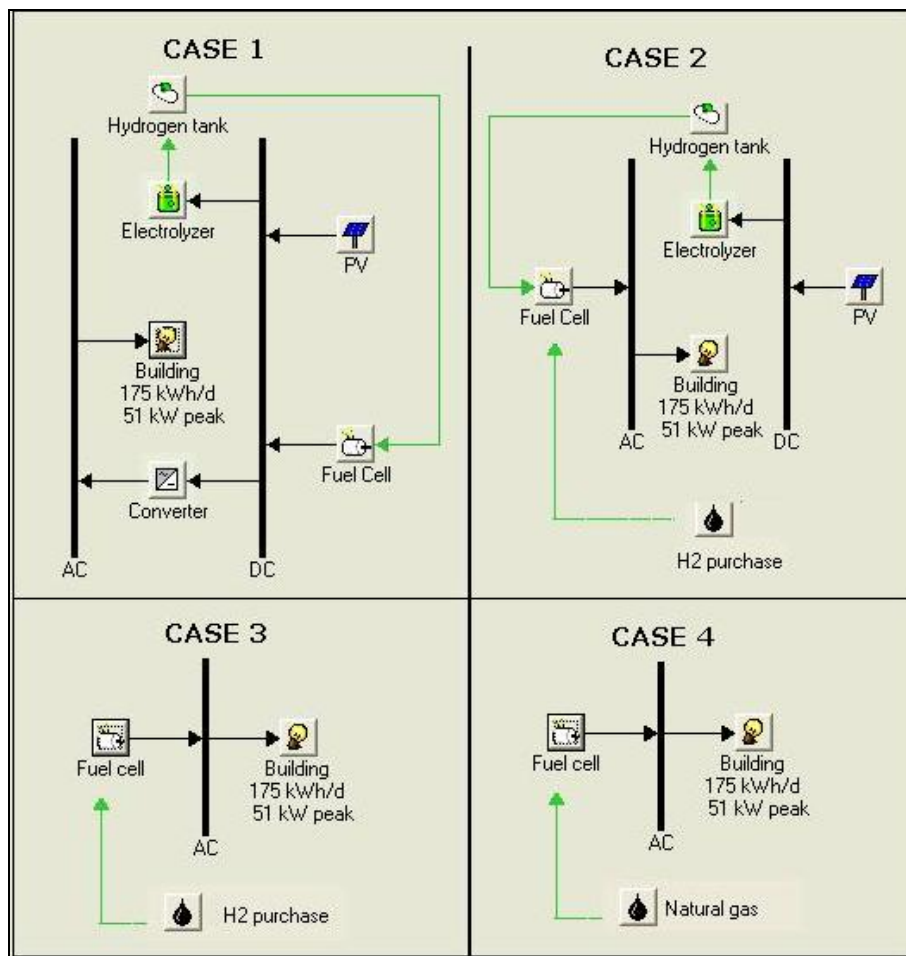

Figure 1: Four different scenarios analyzed with HOMER.

In case 1 the photovoltaic system produces electricity to cover part of the electrical demands, at the same time that produces hydrogen when there is surplus electricity.

To simulate this system, photovoltaic panels, electrolyser, and fuel cell are connected to the DC bus (Figure 1). In this way, HOMER could select the best option between a) to generate electricity from the photovoltaic panels and to consume it directly by the building, or b) to produce hydrogen and to use it when electrical demand exists but photovoltaic generation is not available.

Some simulations have been carried out reducing the self-sufficiency of the building. If all the electrical demand was to be covered, just for the photovoltaic system more than 100 kW will be necessary, so much as for a 600 m² building, when there is only enough space on the roof to install 40 kW aprox. Therefore, the CASE 1 has been developed for 70% self-sufficiency.

The next cases analyzed seem more feasible, because they need less space in the building to install all the components and the system is more cost competitive.

In CASE 2 the fuel cell covers 100% of the electrical demand, thus covering all the power peaks in the building, taking into account the simultaneousness factor. In this case the fuel cell will be oversized, because most of the time it works below its total capacity, as we can see in Figure 4.

In this case hydrogen has two different origins: a small part of the hydrogen is produced on site the building through electrolysis from photovoltaic electricity, and the rest of the hydrogen needed is provided by a specialized company. If this company produces hydrogen from renewable sources as solar thermoelectric, a possible option in Andalucía, the hydrogen will still be renewable even though it is not produced in the building.

To simplify the installation, two different cases have been analyzed.

In CASE 3, instead of producing the hydrogen in the building, it will be totally provided by a specialized company. As we mentioned before, this company could produce the hydrogen from renewable sources leaving fuel free of emission.

In CASE 4, the difference lies in the fact that a natural gas fuel cell has been used. In this case, it is only necessary the natural gas pipelines connected to the building and the hydrogen will be produced within the fuel cell with a reformer.

Under this last option, as well as covering the electrical demands of the building there exists the possibility to use the residual heat from the fuel cell to cover part of the DHW demand and/or the heating demand. The only drawback of this system is that the source of the hydrogen is not renewable.

3 Features of the Components

To analyze the different cases described in the previous section, the software HOMER has been used.

In Table 1, the economical and technical features of the components used in the different simulations are shown. The investment costs of each component are shown in this table, as well as the replacement and O&M costs. In the same way, the lifetime of the photovoltaic modules and electrolyser, the number of operation hours per year of the fuel cell and the electrolyser efficiency are shown.

Table 1: Features of the components.

	Photovoltaic modules	Electrolyser	Fuel cell	H ₂ storage
Investment costs	6,000 €/kW	5,400 €/kW [3]	6,000 €/kW ¹ 3,000 €/kW ²	1,445 €/kg
Replacement costs	4,000 €/kW	2,000 €/kW	4,000 €/kW ¹ 1,500 €/kW ²	1,445 €/kg
O&M costs	300 €/ year	216 €/year	5.5% of the investment costs	0 €/ year
Operation hours			15.000	
Lifetime (year)	35	25		25
Efficiency		65%		

¹ For 1 kW fuel cell, estimated from [4]

² For 20 kW fuel cell, estimated from [4]

In Figure 2, the H₂ fuel cell and NG fuel cell efficiency curves calculated by HOMER are shown. Those curves are calculated according to the fuel consumption and production parameters introduced in the model.

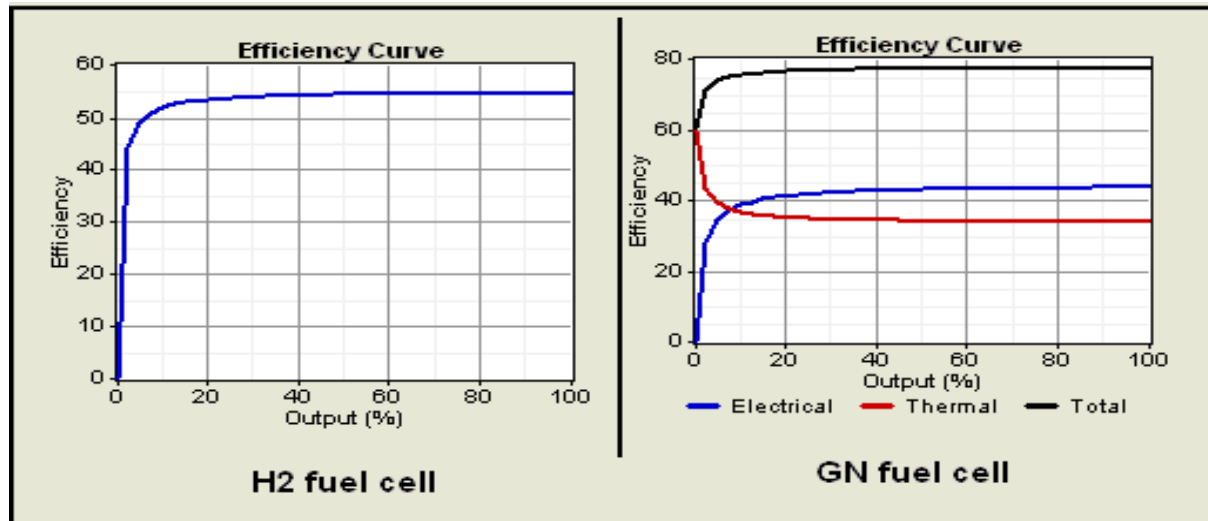

Figure 2: H₂ fuel cell (Left) and NG fuel cell (Right) efficiency curves.

4 Analysis of the Results Obtained from HOMER

The sizes of the equipments used in each case are shown in Table 2, as well as the amount of hydrogen or natural gas purchased when an external supply it is necessary. In this table, we can also see the cost of energy per kWh and the whole system cost for each case.

Table 2: Summary of different cases analyzed.

	P.V. (kW)	F.C. (kW)	Electrolyz (kW)	H ₂ storage (kg)	H ₂ purchase (kg)	Natural Gas (m ³)	COE (€/kwh)	TOTAL (NPC)	CO ₂ emissions avoided (ton)
CASE 1	45	4	30	15			0.8723	829,549	20.3
CASE 2	10	40	9	2.5	3,482		0.977	967,922	29
CASE 3		40			3,810		0.894	804,409	29
CASE 4		40				15,739	0.835	750,938	

P.V.= Photovoltaic array; F.C.= Fuel Cell; COE= Cost Of Energy; NPC=Net Present Cost

According to the results shown in Table 2, the most feasible case from the economical point of view is CASE 4. This case is also the most easy to install and it uses the most reliable technology, because natural gas fuel cells have a longer lifetime than hydrogen fuel cells have. However, in this case the origin of the hydrogen is not renewable.

Among the rest of the cases, CASE 3 is the most the most suitable from the technical and economical point of view. Finally, CASE 1 is more cost-competitive than CASE 2, because in

CASE 1 30% of the electrical demands are covered by the grid and this fact makes the system cheaper.

The operation mode of the main components in CASE 1 (photovoltaic system, fuel cell, hydrogen storage) is shown in Figure 3, reaching a 70% of self-sufficiency.

As shown in this figure, the photovoltaic system works during the day, whereas the fuel cell works during the night or when the solar contribution is not enough. The black colour shows the hours of the day in which fuel cell or photovoltaic modules do not work.

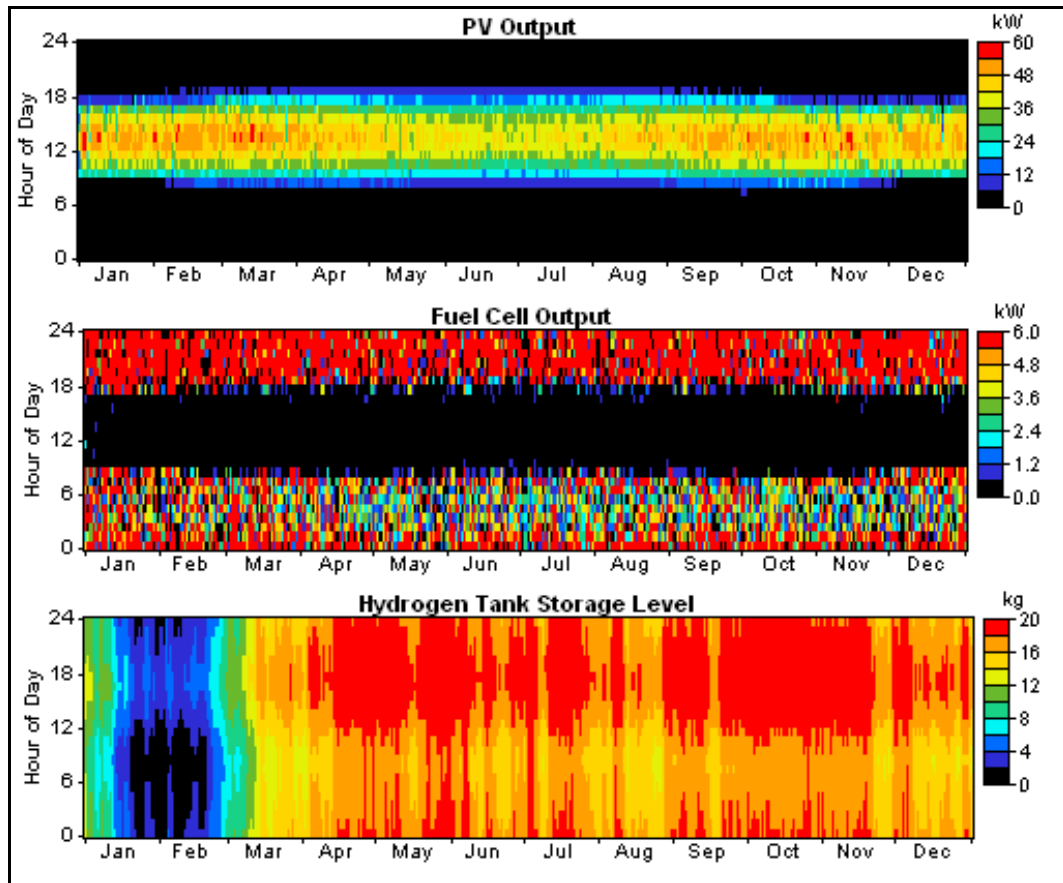

Figure 3: Photovoltaic system, fuel cell and H₂ storage operation mode.

In relation with the hydrogen storage, the following restriction has been made: at the end of the year the level in the hydrogen tank has to be, at least, at the same level as it was at the beginning of the year. In this way, a year is representative of the rest of the period (25 years in all). Therefore, in Figure 4 we can see how the tank is sometimes full during the summer months, while in January and February there is a reduction in the hydrogen storage.

As we have seen before, 45 kW of photovoltaic system are necessary in CASE 1, but this option takes a huge space in the roof. CASE 2, which is a combination of CASE 1 and CASE 3 could clear this problem up.

In CASE 3 and CASE 4 the fuel cell could cover practically 100% of the building demand, but this option is not the most appropriate since the building is connected to the grid, and to cover the peak power with the grid avoiding to oversize the fuel cell is more reasonable.

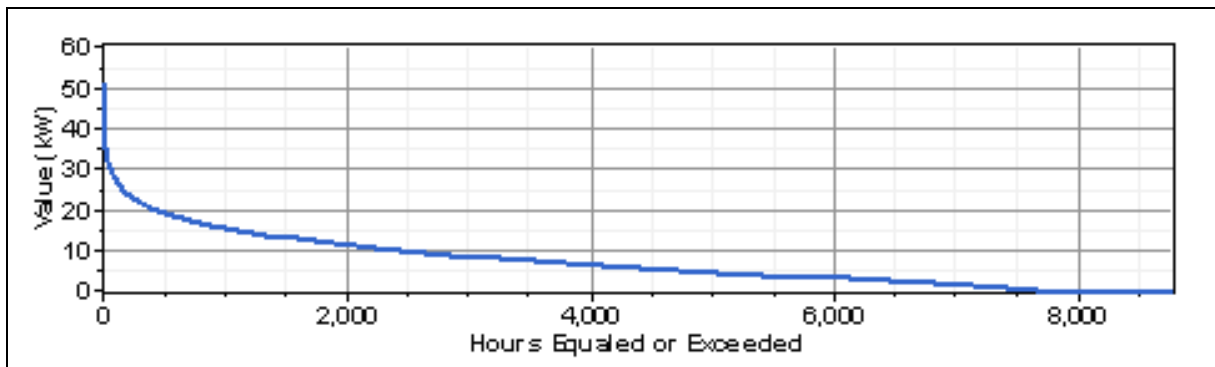

Figure 4: AC primary load duration curve.

In Figure 4, we can see that the power is higher than 40 kW (maximum fuel cell power) only during 7 hours per year. This means that the power grid will need to cover the 0.05% of the whole year demand. A 30 kW fuel cell will be used in order to reduce costs, and in this case the grid will have to cover 60 hours a year.

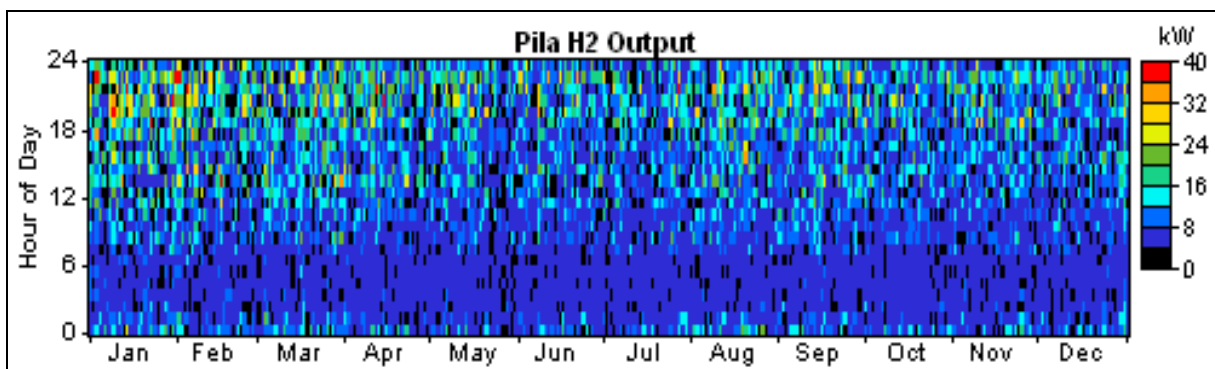

Figure 5: Fuel cell operation mode.

This fact is also shown in Figure 5, where we can see the fuel cell operation mode in CASE 3 and CASE 4. The fuel cell is working below its maximum power during most of the time, and therefore the system costs could be decreased quite a lot if the power peaks were covered from the grid.

5 Conclusions

Different configurations have been analyzed to study the feasibility of a 16 flats building block using hydrogen to cover the electrical demands. Hydrogen could be produced on site through water electrolysis from photovoltaic electricity.

The 100% self-sufficiency is the most restrictive option, as this option is really expensive, has a lot of technical restrictions and takes a lot of space in the roof to install all the components. Therefore other options have been studied.

The first option is to increase the contribution of the grid to cover part of the electrical demands reducing the size of the systems. The second option analyzed is to produce part of the hydrogen on site and to purchase the rest of the needed amount to a specialized

company. In the third option all the hydrogen is purchased, and in the last option a natural gas fuel cell with a reformer is used.

Analyzing all these options the conclusion is that currently the election of most feasible option, taking into account all the barriers related to physical space, lack of technological maturity and regulation, depends on the amount of electrical demand required to be covered from a renewable source to avoid CO₂ emissions, and depends as well on its economical cost.

Hence, the two most feasible options could be the option of using a natural gas fuel cell and the option of purchasing the hydrogen if a free emissions system is preferred.

References

- [1] Action Plan for Energy Efficiency: Realising the Potential. COM(2006)545 final
- [2] <http://www.homerenergy.com/>
- [3] L. S. Basye, S, "Hydrogen Production Costs," U.S. Department of the Environment Report DOE/GO/10170-778, 1997.
- [4] "Gas Fired Distributed Energy Resource Technology Characterization," National Renewable Energy Laboratory 2003