

Atmospheric Measurement Techniques Discussions is the access reviewed discussion forum of *Atmospheric Measurement Techniques*

**Development and
application of a new
mobile LOPAP
instrument**

R. Häseler et al.

Development and application of a new mobile LOPAP instrument for the measurement of HONO altitude profiles in the planetary boundary layer

R. Häseler, T. Brauers, F. Holland, and A. Wahner

ICG-2, Forschungszentrum Jülich, 52425 Jülich, Germany

Received: 6 August 2009 – Accepted: 17 August 2009 – Published: 28 August 2009

Correspondence to: T. Brauers (th.brauers@fz-juelich.de)

Published by Copernicus Publications on behalf of the European Geosciences Union.

Title Page

Abstract

Introduction

Conclusions

References

Tables

Figures

⏪

⏩

◀

▶

Back

Close

Full Screen / Esc

Printer-friendly Version

Interactive Discussion

Abstract

The LOPAP (long path absorption) technique has been shown to be very sensitive for the detection of nitrous acid (HONO) in the atmosphere. However, current instruments were mainly built for ground based applications. Therefore, we designed a new LOPAP instrument to be more versatile for mobile measurements and to meet the requirements for airborne application. The detection limit of the new instrument is below 1 ppt at a time resolution of 5 to 7 min. As a first test, the instrument was successfully employed during the ZEPTEP-1 campaign in July 2007 on board of the Zeppelin NT airship. During 15 flights on six days we measured HONO concentration profiles over southwest Germany, predominantly in the range between 100 m and 650 m above ground level. On average, a mixing ratio of 34 ppt was observed, almost independently of height. Within a second campaign, ZEPTEP-2 in fall 2008, higher HONO mixing ratios were observed in the Lake Constance area.

1 Introduction

Nitrous acid (HONO) is an important precursor for OH radicals in the atmosphere (e.g. Finlayson-Pitts and Pitts, 1999) since it is quickly photolyzed in the sunlight:

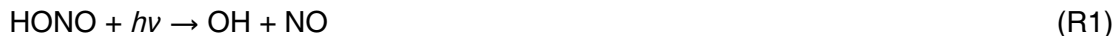

The lifetime of HONO is in the order of 20 min around noon in summer. Recent studies (Zhou et al., 2002; Alicke et al., 2003; Kleffmann et al., 2005; Acker et al., 2006; Su et al., 2008) showed the significant contribution of HONO photolysis to the OH production rate during the entire day. In the gas phase HONO is formed by the reaction of OH with NO



Besides the gas phase source of HONO (R2) heterogeneous sources on surfaces exist, but the picture of the heterogeneous HONO source is not conclusive at the moment

Development and application of a new mobile LOPAP instrument

R. Häseler et al.

Title Page

Abstract

Introduction

Conclusions

References

Tables

Figures

◀

▶

◀

▶

Back

Close

Full Screen / Esc

Printer-friendly Version

Interactive Discussion



(e.g. Kleffmann, 2007). However, lacking understanding of the formation processes of HONO makes it necessary to accurately measure HONO when the budget of OH or NO_x is considered.

Before 2000, HONO measurements were mostly performed using Differential Optical Absorption Spectroscopy (DOAS) (e.g. Platt et al., 1980; Winer and Biermann, 1994) or different types of denuders (e.g. Harrison et al., 1996; Febo et al., 1996; Neftel et al., 1996). In 1999, Long Path absorption (LOPAP) was introduced by Heland et al. (2001) as a new sensitive in situ technique. The LOPAP instrument was applied in field campaigns (e.g. Kleffmann et al., 2003, 2005) and laboratory studies (e.g. Bröske et al., 2003; Rohrer et al., 2005; Stemmler et al., 2007) The instruments were improved by Kleffmann and co-workers and successfully compared to the DOAS technique (Kleffmann et al., 2006). Now it is marketed through QUMA Elektronik & Analytik GmbH (Wuppertal, Germany). However, these instruments were not designed for mobile applications. Therefore, we re-engineered the LOPAP in order to meet the stringent approval requirements for airborne operation.

The LOPAP technique can be explained by a simple flow chart presented in Fig. 1. In a first step the air is pumped through two sampling coils connected in series where the HONO is stripped into the liquid phase. The first coil (channel 1) removes HONO nearly quantitatively from the gas phase but only a small fraction of interfering species. The second coil (channel 2) samples the same fraction of the interfering species but only the remaining small amount of HONO. Using the difference of the signals of channels 1 and 2 strongly reduces the influence of interfering species. The stripping solution (S1) consists of 0.06 M sulfanilamide in a 1 M HCl solution. HONO instantaneously forms a diazonium salt with the stripping solution. The air is separated from the liquid and the solutions are pumped into two independent mixing volumes where a 0.8 mM solution of N-(1-naphthyl)ethylenediamine-dihydrochloride (S2) is injected to form the azo dye. The concentration of the azo dye is then detected by optical absorption. The absorption cells for both channels consist of long length Teflon tubing, acting as liquid core waveguide (LCW). Visible light is sent through the tubing and detected by two

Development and application of a new mobile LOPAP instrument

R. Häseler et al.

[Title Page](#)[Abstract](#)[Introduction](#)[Conclusions](#)[References](#)[Tables](#)[Figures](#)[⏪](#)[⏩](#)[◀](#)[▶](#)[Back](#)[Close](#)[Full Screen / Esc](#)[Printer-friendly Version](#)[Interactive Discussion](#)

mini-spectrometers.

In this study, we present the outline of a new, improved LOPAP instrument which was certified for airborne applications. We also show the first direct measurements of HONO performed aboard an airship (Zeppelin-NT) using the new instrument which we call LOPAP-Z. We sampled various vertical profiles of HONO over Lake Constance and over mainly forested areas in southern Germany. The budget of HONO and its relevance for the OH photochemistry will be discussed in a forthcoming paper (Brauers et al., 2008.)

2 The new LOPAP-Z instrument

Based on the experience with the current LOPAP-3 instruments (marketed by QUMA) and forced by the requirements for airborne application, we redesigned the instrument, but we retained the LOPAP concept (cf. Fig. 1). A ruggedized sampling unit, the use of certified airworthy materials, and the separation of the chemistry part from electronics were required to meet the flight requirements. Additional modifications were demanded by the limited power and space aboard the airship. The entire instrument (Fig. 2) was housed in a 19" rack of 56 cm × 60 cm × 100 cm (width × depth × height).

2.1 Hardware modifications and improvements

The subsequent list compares the hardware of the LOPAP-Z to the instrument described by Kleffmann et al. (2006).

- Optimized and ruggedized sampling unit for mobile applications: the new sampling unit (Fig. 3) consists of a stripping coil which is integrated in a solid glass cylinder having the sampling inlet on one end surface and all connectors on the other surface. The entire sampling unit is made of glass. The stripping coil of 17 cm length, and 2 mm i.d. is similar to the original design, also providing a high sampling efficiency for HONO. In order to minimize sampling artifacts the length

Development and application of a new mobile LOPAP instrument

R. Häseler et al.

Title Page

Abstract

Introduction

Conclusions

References

Tables

Figures

⏪

⏩

◀

▶

Back

Close

Full Screen / Esc

Printer-friendly Version

Interactive Discussion



Development and application of a new mobile LOPAP instrumentR. Häseler et al.

[Title Page](#)[Abstract](#)[Introduction](#)[Conclusions](#)[References](#)[Tables](#)[Figures](#)[⏪](#)[⏩](#)[◀](#)[▶](#)[Back](#)[Close](#)[Full Screen / Esc](#)[Printer-friendly Version](#)[Interactive Discussion](#)

of the sampling inlet is only 5 cm. To avoid photochemical reactions in the gas and liquid phase inside the sampling unit it is shielded against daylight. The zero air is internally injected by a glass line directly into the inlet line of the stripping coil. For flight operation, the sampling unit was designed to have a low weight and small size. The small size minimizes the drag from the wind when the sampling unit sticks out of the window of the Zeppelin (cf. Fig. 5). Good thermal insulation reduced the requirements for the cooler.

- Thermoelectric Peltier coolers: the sampling loop of the LOPAP-3 was kept at a constant temperature by a laboratory compressor liquid bath cooler. For LOPAP-Z we replaced the cooler by a small-sized (300 mm × 152 mm × 105 mm) air-to-liquid Peltier cooler (LA-160-24-02-00-00, Supercool, Sweden). An additional air-to-air Peltier cooler (LA-160-24-22-00-00, Supercool, Sweden) is used to control the temperature in the chemistry unit.
- Improved optics: similar to the instrument described by Kleffmann et al. (2006) we used white light-emitting LEDs (Lumileds, Typ: LUXEON V star white, LXHL-LW6C) instead of halogen lamps as in the original design of Heland et al. (2001). The light from these diodes is transferred to the absorption path by fiber optics (OZ-Optics, Multimode Fiber QMMJ-55-UVVIS-600/660-3-x). Different from the original design we use small lenses to focus the light into the absorption path (liquid core waveguide LCW) made of Teflon tubing (AF 2400). This separates the fiber from the liquid and reduces the risk of leaks. The size of the dead volume is not affected. We also replaced the spectrometers (Ocean Optics, SD 2000) by new USB spectrometers (OMT, ctf-60) which provide a high stability and low noise.
- Electronic I/O interface: the components of the LOPAP-Z (with exception of the spectrometers), are interfaced through one I/O board. This board provides the data and settings of the flow controller, valves, pumps, LEDs, and temperatures

Development and application of a new mobile LOPAP instrumentR. Häseler et al.

Title Page

Abstract

Introduction

Conclusions

References

Tables

Figures

◀

▶

◀

▶

Back

Close

Full Screen / Esc

Printer-friendly Version

Interactive Discussion

to the single board computer, where these data are simultaneously recorded with every spectrum.

- Separated units: the different modules of the instrument were separated into three units: 1. electronics unit containing the power supplies for all components, the spectrometers and LEDs, and the interface and computer boards, 2. supply of chemicals in a spill proof containment, and 3. the thermostatic liquid chemistry unit containing the pumps, flow controllers, and optical paths (see setup in Fig. 2). All units are in enclosed containments to meet the certification requirements.
- Low weight, low power consumption: the total weight including a set of chemicals is 75 kg. The power consumption of the entire instrument during operation is 250 W. The peak power reaches 800 W during startup and heavy cooling.
- Certification for air-borne operation: the instrument was certified by Zeppelin Luftfahrttechnik for mechanical stability, electrical safety, fire safety, and safe containment for chemicals and waste.

2.2 The LOPAP-Z software and evaluation procedure

The new hardware components required new software for the automatic operation. We developed a C++ program (AICONS) which controls all components (spectrometers, mass flow controllers, pumps, thermostats) through one interface (Ehmer, 2009). The data is automatically stored in netCDF¹ format. However, during the campaigns described in the result section of this paper we used the aSpect2.8 software (OMT) to record the spectra since the Aicons software was not yet fully operational.

The procedure for converting the measured absorption spectra into HONO mixing ratios starts with the calculation of the relative absorbance $A = \log(I_{650\text{ nm}}/I_{550\text{ nm}})$ for

¹NetCDF (network Common Data Form) software libraries and data formats, see <http://www.unidata.ucar.edu/software/netcdf/>

Development and application of a new mobile LOPAP instrumentR. Häseler et al.

[Title Page](#)[Abstract](#)[Introduction](#)[Conclusions](#)[References](#)[Tables](#)[Figures](#)[⏪](#)[⏩](#)[◀](#)[▶](#)[Back](#)[Close](#)[Full Screen / Esc](#)[Printer-friendly Version](#)[Interactive Discussion](#)

both channels, where 650 nm and 550 nm are the measurement wavelength and reference wavelength, respectively. In the next step we determine the zero point absorption for both channels from frequent measurements of synthetic air. These values are used to correct the absorbance in both channels. In a third step, we convert the absorbance into NO_2^- concentrations using the flow rates and the calibration curve independently determined using a liquid standard. Finally, the HONO mixing ratio is calculated from the air flow rate, the sampling efficiency, and the NO_2^- concentrations of both channels. We use gaussian error propagation to calculate the systematic error.

The spectra were recorded at rate of 5 s. However, the time resolution of the instrument is between 5 min and 8 min depending on the flow rate of the liquids through the absorption path. The time resolution was independently determined when zero point measurement were started and ended. For this study we converted the 5 s original data to 5 min averages which are shown in the figures.

2.3 Characterization by laboratory tests

Before and after the field campaigns some important parameters of the LOPAP-Z were determined by a number of tests in the laboratory.

- Water dependence of sampling: a critical parameter for the conversion of signals in to HONO mixing ratios is the flow rate of the chemical through the sampling unit. When the sampled air is dry (i.e. at low relative humidity with respect to the temperature in the sampling unit) a small fraction of water in the flow of chemicals in channel 1 is evaporated into the gas phase and thus changes the concentration of the reactants for the subsequent analysis. Due to changing water content during the flight operation (i.e. change in altitude and air mass) we calculated a time dependent factor from the absolute humidity during the flights.
- Determination of the sampling efficiency: for the current sampling unit we determined the sampling efficiency at three different flow rates (1000 ml/min, 1500 ml/min, and 2000 ml/min). The HONO source was a thermostated (15°C)

Development and application of a new mobile LOPAP instrument

R. Häseler et al.

[Title Page](#)[Abstract](#)[Introduction](#)[Conclusions](#)[References](#)[Tables](#)[Figures](#)[⏪](#)[⏩](#)[◀](#)[▶](#)[Back](#)[Close](#)[Full Screen / Esc](#)[Printer-friendly Version](#)[Interactive Discussion](#)

wash bottle with 200 ml H_2SO_4 (0.02 N) and 20 ml NaNO_2 (0.2 mg/l). During the Zeppelin flights the flow rate was set to 1500 ml/min which resulted in the best sensitivity. We used a sampling efficiency of 95.14% for the evaluation of the data.

- 5 – Intercomparison to previous instruments: as part of the performance tests of the new instrument we performed an intercomparison to the existing LOPAP-3 instrument. We sampled air through an inlet line through the window of the lab and split the air through a T-connector into the instruments.

The result of the pre-campaign laboratory intercomparison is shown in Fig. 4. Both instruments agree within the error of the single instrument. A disadvantage of this test was the sampling configuration which introduced a Teflon line before the sampling loop inlet. It is planned, however, to repeat this test under the well controlled conditions of the atmosphere simulation chamber SAPHIR at Jülich.

- 15 – Stability, precision, detection limit, and accuracy: during the laboratory measurement period, we tested the stability of the instrument reading when fed with synthetic air. Typically we observed a combination of signal drift and noise which was in the range of 1 ppt and below. From these measurements we obtained a detection limit of 0.7 ppt ($2\text{-}\sigma$) for a time resolution of 5 min. The precision is 1.2 ppt (at 100 ppt HONO mixing ratio). The measurement range of the instrument can be varied by the length of the absorption tubes and by the use of different absorption wavelengths for the evaluation (Heland et al., 2001). In this study we used an optical path length of 2.9 m. From the calibrations we calculate an accuracy of 6% which represents the $2\text{-}\sigma$ error of the sensitivity.
- 20

3 The Zeppelin airship and the ZEPTER campaigns

25 The LOPAP-Z instrument was designed and setup in the first half of 2007. During two field campaigns, it was employed on a Zeppelin NT airship for 15 flights in July 2007

and 25 flights in October/November 2008.

3.1 Zeppelin NT airship

The Zeppelin NT semi-rigid airship is an engine-driven, near-equilibrium, steerable aircraft. A vectored thrust propulsion system can give additional lift and an accurate steering capability at low speed. Three engines provide the power for the airship. The airship is build around a framework of triangular carbon-fibre frames connected by aluminum longerons. The cabin, empennage, and engines are mounted on this rigid structure. The pressurized envelope of the Zeppelin NT, which is made of a multi-layer laminate fabric, encloses a volume of 8450 m³. The total dimensions of the Zeppelin NT are 75.0 m length, 19.5 m width, and 17.4 m height (Fig. 5). The airship body consists of a carrier gas cell which is filled with non-flammable helium and two internal air cells (ballonets). The gondola of the Zeppelin carried most of the scientific instruments. The seats were removed to give space for five 19" standard racks. Electrical power is supplied by the airship for the instruments (entirely 220 A at 28 V DC). A detailed description of the Zeppelin-NT and its capabilities for scientific explorations will be described by Oebel et al. (2009).

3.2 ZEPTER campaigns

The measurements during the ZEPTER campaigns were performed during 18 flights in July 2007 and 25 flights in October/November 2008 (see Tables 1 and 2). The first campaign (ZEPTER-1) was intended as a first test for the instruments and the integration aboard the airship. However, it was also thought as an addition to the field campaign COPS-TRACKS (Wulfmeyer and Behrendt, 2007). The second campaign was a test campaign for the OH and HO₂ LIF instrument. In addition, these flights were embedded into a program of measurements above different land cover. It was accompanied by local ground based measurements.

The LOPAP-Z instrument participated in all flights of both campaigns, however,

Development and application of a new mobile LOPAP instrument

R. Häseler et al.

Title Page

Abstract

Introduction

Conclusions

References

Tables

Figures

⏪

⏩

◀

▶

Back

Close

Full Screen / Esc

Printer-friendly Version

Interactive Discussion

during flights F01, F04, and F15 in 2007 and F12 and F23 in 2008 no data were recorded due to technical problems. The flights in 2007 were carried out during daytime only (Table 1) during ZEPTEP-1 while ZEPTEP-2 had night flights as well (Table 2). The detailed flight tracks and the instrumentation during the flights are available from <http://zeppelin.fz-juelich.de>.

4 Exemplary measurements of HONO

4.1 ZEPTEP-1

The ZEPTEP-1 campaign in July 2007 was the first test not only for the new LOPAP-Z instrument but also for the integration of all instruments aboard the Zeppelin NT airship (Oebel et al., 2009). Therefore, the flight tracks and maneuvers were often determined based on technical issues, rather than atmospheric chemistry issues. Here, we present all measured HONO data in 5 min time resolution. The HONO measurements were partly accompanied by simultaneous recordings of NO_x , O_3 , HCHO, CO, VOCs, photolysis frequencies, and other parameters, which will be published separately.

During 15 flights we measured HONO mixing ratios with the LOPAP-Z (Fig. 6) mainly covering the range from 100 m to 600 m height above the ground, corresponding to approximately 300 m to 900 m above sea level. The flights F02–F09 were performed around Friedrichshafen, Lake Constance area. Flight F05, during afternoon hours, showed low, almost constant values (30 ppt) from 50 m to 750 m. Flight F08, performed in early morning hours showed values all below 100 ppt. Interestingly, the highest values of 100 ppt were observed in the first ascent of the airship, while later profiles are at 30 ppt only. This effect is probably driven by sunlight photolyzing HONO via reaction R1. The other profiles in the Friedrichshafen area are characterized by higher HONO concentrations. The flights F01–F08 were not accompanied by full sets of other measurements since the flights were mainly used for integration tests. The flights were carried out at very similar temperatures from 286 K to 296 K. Two transfer flights

Development and application of a new mobile LOPAP instrument

R. Häseler et al.

Title Page

Abstract

Introduction

Conclusions

References

Tables

Figures

⏪

⏩

◀

▶

Back

Close

Full Screen / Esc

Printer-friendly Version

Interactive Discussion

Development and application of a new mobile LOPAP instrumentR. Häseler et al.

[Title Page](#)[Abstract](#)[Introduction](#)[Conclusions](#)[References](#)[Tables](#)[Figures](#)[⏪](#)[⏩](#)[◀](#)[▶](#)[Back](#)[Close](#)[Full Screen / Esc](#)[Printer-friendly Version](#)[Interactive Discussion](#)

(F10 and F18) from Friedrichhafen to Baden Airpark went along the valleys of the Black Forest. While F18 shows low values throughout the flight, F10 exhibit one large spike (exceeding the 0.5 ppb range of Fig. 6) which was not seen in other trace gas measurements. However, the inlet for the NO_x, O₃, and CO instruments was at the top platform, approximately 20 m above the inlet of the LOPAP-Z. The flights out of Baden airpark (F11–F17) were intended to study the photochemistry over different places as a contribution to the COPS-TRACKS project. The values observed here are well below 200 ppt for all flights. The spike in F17 corresponds to high values in the NO_x measurements as well and points to a plume of polluted air.

Figure 7 presents the summary of all data recorded with the LOPAP-Z instrument as a function of the height of the airship above ground. The majority of the measurements were made between 100 m and 600 m. If the data are analyzed in 50 m height intervals the median mixing ratio does not show a large variation between 100 m and 650 m where the number of data points per interval is high enough to provide a meaningful analysis of the distribution within the 50 m interval. We find that the median varies between 30 ppt and 50 ppt indicating no significant altitude dependence in this range of altitudes.

4.2 ZEPTEP-2

The ZEPTEP-2 campaign took place from 17 October 2008 to 8 November 2008 out of Friedrichhafen airport (FDH). All flights were within 100 km from FDH, which is the maximum range for the airship for a round-trip with the payload described in Table 2. The focus of the campaign was twofold: firstly, for integration and initial testing of the instruments aboard the airship and secondly, on the influence of different surfaces (forests, agricultural areas) on the composition and chemistry of the atmospheric boundary layer. The test flights (F01 to F07) were operated with a reduced set of instruments intended to integrate the HO_x instruments (see Table 2). The LOPAP-Z was successfully operated aboard the Zeppelin NT, during the ZEPTEP-2 campaign and was able to deliver data for 23 out of 25 flights (Fig. 8).

Development and application of a new mobile LOPAP instrumentR. Häseler et al.

[Title Page](#)[Abstract](#)[Introduction](#)[Conclusions](#)[References](#)[Tables](#)[Figures](#)[I◀](#)[▶I](#)[◀](#)[▶](#)[Back](#)[Close](#)[Full Screen / Esc](#)[Printer-friendly Version](#)[Interactive Discussion](#)

Compared to July 2007 the values are generally higher, often between 100 ppt and 200 ppt. Several data sets show a pronounced vertical profile, i.e. F02, F04, F07, and F16. These flights were carried out around noon when the HONO lifetime is relatively short due to photolysis. However, at this time of the year, the HONO photolysis is about 30% lower than in July. Several data sets show spikes even extending the range of Fig. 8.

An overview on all data sets (Fig. 9) shows the enormous variation. The majority of the data is between 70 ppt and 300 ppt, with a median of 150 ppt, well above the range found in the ZEPTEP-1 campaign. The box-whisker plot indicates an average profile which decreases from 200 ppt at 100 m altitude to \approx 100 ppt at 700 m.

In contrast to the 2007 campaign, we also conducted flights after sunset. The data were separated in two subsets selected by the solar zenith angle (SZA) being less or greater than 90° . The frequency distributions (Fig. 10) show no significant difference between the subsets. Both exhibit a similar nearly log-normal distribution of the data centered around 150 ppt. The majority of the night data were recorded in the evening, shortly after sunset. Altitude profiles obtained during the entire night would be a worthwhile extension in order to compare these to ground based measurement which generally exhibit nighttime maxima.

5 Conclusions and outlook

A new mobile LOPAP-Z instrument, certified for flight operation, was designed and tested. It was successfully operated during 38 flights aboard an airship. For the first time the airship Zeppelin NT was equipped with a comprehensive set of instruments to investigate the photochemical state of the planetary boundary layer. The measured HONO mixing ratios in the altitude range between 100 m and 950 m (above ground) were between the detection limit of 5 ppt and a maximum of 1 ppb. However, for the summer 2007, the median altitude profile between 100 m and 1000 m was almost constant at 35 ppt while in the fall 2008 the values were apparently higher. The presented

HONO mixing ratios and their variability show the importance of direct HONO measurements when the fast photochemistry of HO_x radicals is studied.

The instrument was designed to operate reliably and to meet the safety requirements of mobile operations, e.g. by clearly separating liquids from electronics into sealed compartments. The concepts and the instrument layout presented here might also be applied to instruments measuring other species. In the meantime LOPAP has been extended to measure HNO₃ (Kleffmann et al., 2007) and NO₂ (Villena Tapia et al., 2008).

Appendix A

Flight information

The flights of the ZEPTER campaigns were carried out in south west Germany. Tables 1 and 2 provide an overview on the flights and the general concept. Detailed data on the instrumentation of the Zeppelin, flight tracks, and meteorological conditions are available from the campaigns' web site at <http://zeppelin.fz-juelich.de>. Here, we only give a general outline of the flights.

The flight plans were based on status and availability of instruments and the weather conditions, i.e. the airship cannot be operated at low visibility, high wind speeds, or in thunder or hail storms. The duration of the flights was between 1 h and 4 h. In most cases the measurements close to the airport (below 100 m height) were strongly influenced by local pollution. Those measurements are not included.

Acknowledgements. The authors thank all participants of the ZEPTER campaigns, namely A. Hofzumahaus and F. Rohrer for good collaboration. We thank J. Ehmer for programming support and the AICONS software. The authors wish to thank the crew of the ZLT Zeppelin Luftschifftechnik GmbH and the Deutsche Zeppelin-Reederei GmbH for their helpful cooperation and their support of the field campaigns. Financial support of BMBF is acknowledged (Förderkenzeichen 01LG0602 and 01LP0802A).

Development and application of a new mobile LOPAP instrument

R. Häseler et al.

Title Page

Abstract

Introduction

Conclusions

References

Tables

Figures

◀

▶

◀

▶

Back

Close

Full Screen / Esc

Printer-friendly Version

Interactive Discussion



References

- Acker, K., Möller, D., Wieprecht, W., Meixner, F., Bohn, B., Gilge, S., Plass-Dülmer, C., and Berresheim, H.: Strong production of OH from HNO₂ at a rural mountain site, *Geophys. Res. Lett.*, 33, L02 809, doi:10.1029/2005GL024643, 2006. 2028
- 5 Aliche, B., Geyer, A., Hofzumahaus, A., Holland, F., Konrad, S., Pätz, H., Schäfer, J., Stutz, J., Volz-Thomas, A., and Platt, U.: OH formation by HONO photolysis during the BERLIOZ experiment, *J. Geophys. Res.*, 108, 8247–8263, doi:10.1029/2001JD000579, 2003. 2028
- Brauers, T., Häseler, R., Bohn, B., Holland, F., Rohrer, F., Tillmann, R., and Wahner A.: Measurement of HONO altitude profiles in the planetary boundary layer, manuscript in preparation, 2009.
- 10 Bröske, R., Kleffmann, J., and Wiesen, P.: Heterogeneous conversion of NO₂ on secondary organic aerosol surfaces: A possible source of nitrous acid (HONO) in the atmosphere?, *Atmos. Chem. Phys.*, 3, 469–474, 2003, <http://www.atmos-chem-phys.net/3/469/2003/>. 2029
- 15 J. Ehmer: AICONS for LOPAP (Automated Instruments Control Software): Ein Programm zur automatisierten Messdatenerfassung und Steuerung des LOPAP Messinstruments mit Hilfe einer graphischen Benutzeroberfläche; Bachelor Thesis, FH Jülich, 2009(in German).
- Febo, A., Perrino, C., and Allegrini, I.: Measurement of nitrous acid in Milan, Italy, by DOAS and diffusion denuders, *Atmos. Environ.*, 30, 3599–3609, 1996. 2029
- 20 Finlayson-Pitts, B. J. and Pitts, J. N.: *Chemistry of the Upper and Lower Atmosphere – Theory, Experiments and Applications*, Academic Press, San Diego, 1999. 2028
- Harrison, R., Peak, J., and Collins, G.: Tropospheric cycle of nitrous acid, *J. Geophys. Res.*, 30, 14429–14439, doi:10.1029/96JD00341, 1996. 2029
- Heland, J., Kleffmann, J., Kurtenbach, R., and Wiesen, P.: A new instrument to measure gaseous nitrous acid (HONO) in the atmosphere, *Environ. Sci. Technol.*, 35, 3207–3212, doi:10.1021/es000303t, 2001. 2029, 2031, 2034, 2045
- 25 Kleffmann, J.: Daytime sources of nitrous acid (HONO) in the atmospheric boundary layer, *Chemphyschem*, 8, 1137–1144, doi:10.1002/cphc.200700016, 2007. 2029
- Kleffmann, J., Kurtenbach, R., Lorzer, J., Wiesen, P., Kalthoff, N., Vogel, B., and Vogel, H.: Measured and simulated vertical profiles of nitrous acid – Part I: Field measurements, *Atmos. Environ.*, 37, 2949–2955, 2003. 2029
- 30 Kleffmann, J., Gavriloaiei, T., Hofzumahaus, A., Holland, F., Koppmann, R., Rupp, L.,

Development and application of a new mobile LOPAP instrument

R. Häseler et al.

Title Page

Abstract

Introduction

Conclusions

References

Tables

Figures

◀

▶

◀

▶

Back

Close

Full Screen / Esc

Printer-friendly Version

Interactive Discussion

Development and application of a new mobile LOPAP instrument

R. Häsel et al.

Title Page

Abstract

Introduction

Conclusions

References

Tables

Figures

◀

▶

◀

▶

Back

Close

Full Screen / Esc

Printer-friendly Version

Interactive Discussion

Schlosser, E., Siese, M., and Wahner, A.: Daytime formation of nitrous acid: a major source of OH radicals in a forest, *Geophys. Res. Lett.*, 32, L05818, doi:10.1029/2005GL022524, 2005. 2028, 2029

Kleffmann, J., Lörzer, J., Wiesen, P., Kern, C., Trick, S., Volkamer, R., Rodenas, M., and Wirtz, K.: Intercomparison of the DOAS and LOPAP techniques for the detection of nitrous acid (HONO), *Atmos. Environ.*, 40, 3640–3652, doi:10.1016/j.atmosenv.2006.03.027, 2006. 2029, 2030, 2031

Kleffmann, J., Gavriloaiei, T., Elshorbany, Y., Rodenas, M., and Wiesen, P.: Detection of nitric acid (HNO₃) in the atmosphere using the LOPAP technique, *J. Atmos. Chem.*, 58, 131–149, 2007. 2039

Kottmeier, C. and Höller, H. with contributions by Beheng, K., Raschke, E., Quante, M., Rockel, B., Lüpkes, C., Smit, H., and Hofzumahaus A.: Transport and Chemical Conversion in Convective Systems (TRACKS) Conception of a Three-stage Large-scale Experiment Section Atmosphere and Climate HGF Research Area Earth and Environment, <http://www.imk.uni-karlsruhe.de/download/tracks-eng-150dpi.pdf>, 2008.

Neftel, A., Blatter, A., Hesterberg, R., and Staffelbach, T.: Measurements of concentration gradients of HNO₂ and HNO₃ over a semi-natural ecosystem, *Atmos. Environ.*, 30, 3017–3025, doi:10.1016/1352-2310(96)00011-8, 1996. 2029

Oebel, A., Hofzumahaus, A., Holland, F., Broch, S., Raak, D., Rohrer, F., Bohn, B., Wahner, A., Gritzbach, R., and Steinlein, K.: Zeppelin NT: A new measurement platform for studies of photochemistry in the lower troposphere, *Atmos. Meas. Techn.*, in preparation, 2009. 2035, 2036

Platt, U., Perner, D., Harris, G., Winer, A., and Pitts Jr, J.: Observation of nitrous acid in an urban atmosphere by differential optical absorption, *Nature*, 285, 312–314, doi:10.1038/285312a0, 1980. 2029

Rohrer, F., Bohn, B., Brauers, T., Brüning, D., Johnen, F.-J., Wahner, A., and Kleffmann, J.: Characterisation of the photolytic HONO-source in the atmosphere simulation chamber SAPHIR, *Atmos. Chem. Phys.*, 5, 2189–2201, 2005, <http://www.atmos-chem-phys.net/5/2189/2005/>. 2029

Stemmler, K., Ndour, M., Elshorbany, Y., Kleffmann, J., D’Anna, B., George, C., Bohn, B., and Ammann, M.: Light induced conversion of nitrogen dioxide into nitrous acid on submicron humic acid aerosol, *Atmos. Chem. Phys.*, 7, 4237–4248, 2007, <http://www.atmos-chem-phys.net/7/4237/2007/>. 2029

Development and application of a new mobile LOPAP instrumentR. Häselser et al.

[Title Page](#)[Abstract](#)[Introduction](#)[Conclusions](#)[References](#)[Tables](#)[Figures](#)[I◀](#)[▶I](#)[◀](#)[▶](#)[Back](#)[Close](#)[Full Screen / Esc](#)[Printer-friendly Version](#)[Interactive Discussion](#)

- Su, H., Cheng, Y. F., Shao, M., Gao, D. F., Zeng, L. M., Slanina, J., Zhang, Y. H., and Wiedensohler, A.: Nitrous acid (HONO) and its daytime sources at a rural site during the 2004 PRIDE-PRD experiment in China, *J. Geophys. Res.*, 113, D14312, doi:10.1029/2007JD009060, 2008. 2028
- 5 Villena Tapia, G., Bejan, I., Wiesen, P., and Kleffmann, J.: Intercomparison of a new ultra-sensitive NO₂-LOPAP against commercial NO₂ instruments and the FTIR technique, poster presented at EGU General Assembly, Geophysical Research Abstracts, Vol. 10, EGU2008-A-07742, 2008 SRef-ID: 1607-7962/gra/EGU2008-A-07742, Vienna, 2008.
- 10 Winer, A. M. and Biermann, H. W.: Long pathlength differential optical absorption spectroscopy (DOAS) measurements of gaseous HONO, NO₂ and HCHO in the California south coast air basin, *Res. Chem. Intermediat.*, 20, 423–445, 1994. 2029
- Wulfmeyer, V. and Behrendt, A., Convective and Orographically induced Precipitation Study, <http://cops.uni-hohenheim.de/>, 2008
- 15 Zhou, X. L., Civerolo, K., Dai, H. P., Huang, G., Schwab, J., and Demerjian, K.: Summertime nitrous acid chemistry in the atmospheric boundary layer at a rural site in New York State, *J. Geophys. Res.*, 107 (D21), 4590, doi:10.1029/2001JD001539, 2002. 2028

Table 1. List of all flights (ZEPTEr-1, 2007) with measurements of HONO by the new LOPAP-Z instrument. VP: vertical profiles, IT: instrument tests, EE: entrainment experiment, and TF: transfer flights (^a: Transfer from airport Friedrichshafen, FDH, to Baden Airpark, FKB. ^b: Transfer from FKB to FDH). Cabin layouts: CL4: reduced set of instruments for test (HO_x, NO_x, O₃, HONO, photolysis frequencies, and MaxDOAS), CL3: CL4 plus HCHO and filter sampling, CL2: CL4 plus CO and VOC, CL1: full set of instruments (CL4 plus HCHO, filter sampling, CO, VOC, and isotopes).

Date 2008	Flight #	Location	Start UTC	End UTC	Ceiling [m] (AGL)	flight design	cabin layout
16 Jul	F02	Lake Constance	12:15	13:57	563	VP	CL1
16 Jul	F03	Lake Constance	14:45	16:49	596	VP	CL1
17 Jul	F05	Lake Constance	14:05	18:35	737	VP, IT	CL2
18 Jul	F06	Lake Constance	08:01	09:00	953	VP	CL1
18 Jul	F07	Lake Constance	15:50	17:19	558	VP, IT	CL1
20 Jul	F08	Lake Constance	04:35	05:45	650	VP	CL3
21 Jul	F09	Lake Constance	04:10	05:45	640	VP,IT	CL3
21 Jul	F10	Transfer ^a	11:50	14:29	554	TF	CL3
21 Jul	F11	Bienwald	15:04	16:45	832	VP	CL3
23 Jul	F12	Murgtal	04:15	08:50	499	EE, VP	CL1
23 Jul	F13	Murgtal	14:45	16:49	530	EE, VP	CL1
25 Jul	F14	Bienwald	04:57	08:28	471	VP	CL1
25 Jul	F16	Karlsruhe, Bienwald	13:24	18:25	455	CP, VP	CL1
26 Jul	F17	Bienwald	04:12	07:29	649	VP	CL1
26 Jul	F18	Tranfer ^b	07:52	11:35	518	TF	CL1

Development and application of a new mobile LOPAP instrument

R. Häseler et al.

Title Page

Abstract

Introduction

Conclusions

References

Tables

Figures

◀

▶

◀

▶

Back

Close

Full Screen / Esc

Printer-friendly Version

Interactive Discussion

Table 2. List of all flights (ZEPTEr-2, 2008) with measurements of HONO by the LOPAP-Z instrument. All flights were carried out starting at Friedrichshafen (FDH). VP: vertical profiles, CLF: constant layer flights. Cabin layouts: CL4: reduced set of instruments for test (HO_x , NO_x , O_3 , HONO and photolysis frequencies and MaxDOAS), CL1: full set of instruments (CL4 plus CO, HCHO, VOC, CPC, and SMPS).

Date 2008	Flight #	Location	Start UTC	End UTC	Ceiling [m] (AGL)	flight design	cabin layout
17 Oct	F01	Lake Constance	17:20	19:32	916	VP	CL4
18 Oct	F02	Lake Constance	09:45	14:08	821	VP	CL4
18 Oct	F03	Lake Constance	14:11	17:45	768	VP	CL4
19 Oct	F04	Ravensburg, Altdorfer Forest	08:45	13:25	688	VP	CL4
19 Oct	F05	Ravensburg, Altdorfer Forest	13:42	17:36	784	VP	CL4
20 Oct	F06	Lake Constance	04:43	10:50	840	VP	CL4
20 Oct	F07	Lake Constance	11:26	17:18	785	VP	CL4
24 Oct	F08	Lake Constance	14:38	18:08	1003	VP	CL1
25 Oct	F09	Lake Constance	13:20	16:44	1002	VP	CL1
26 Oct	F10	Altdorfer Forest	12:40	17:01	795	VP	CL1
26 Oct	F11	Altdorfer Forest	17:40	20:45	945	VP	CL1
31 Oct	F13	Lake Constance	15:04	17:54	784	CLF	CL1
2 Nov	F14	Tettlinger Forest	11:02	14:31	597	CLF	CL1
2 Nov	F15	Tettlinger Forest	15:15	17:57	389	CLF	CL1
3 Nov	F16	Ravensburg, Altdorfer Forest	10:07	13:40	566	VP	CL1
3 Nov	F17	Ravensburg, Altdorfer Forest	14:10	17:37	663	VP	CL1
3 Nov	F18	Ravensburg, Altdorfer Forest	18:01	20:59	695	VP	CL1
5 Nov	F19	Hinterland of Lake Constance	10:44	14:31	525	CLF, VP	CL1
5 Nov	F20	Lake Constance	15:50	20:28	391	CLF	CL1
7 Nov	F21	Hinterland of Lake Constance	09:09	13:25	1001	CLF, VP	CL1
7 Nov	F22	Hinterland of Lake Constance	15:07	16:40	899	CLF, VP	CL1
8 Nov	F24	Hinterland of Lake Constance	11:09	14:14	933	CLF, VP	CL1
8 Nov	F25	Lake Constance	14:33	17:19	890	VP	CL1

Development and application of a new mobile LOPAP instrument

R. Häseler et al.

Title Page

Abstract

Introduction

Conclusions

References

Tables

Figures

◀

▶

◀

▶

Back

Close

Full Screen / Esc

Printer-friendly Version

Interactive Discussion

Development and application of a new mobile LOPAP instrument

R. Häseler et al.

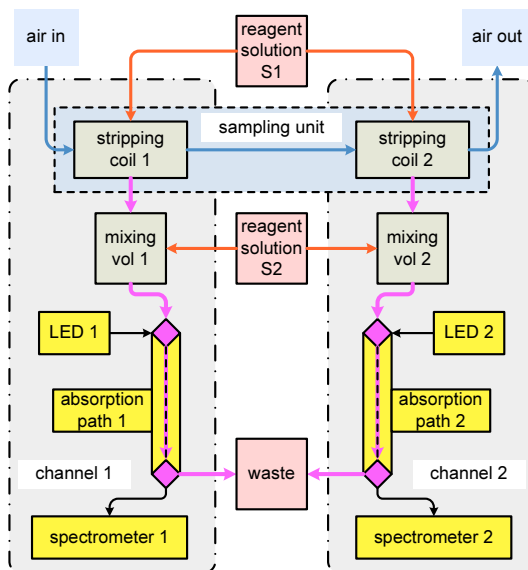

Fig. 1. Flow scheme of a LOPAP instrument (after Heland et al., 2001): air (blue) is sampled into two stripping coils which are operated in series. In both coils the air is exposed to equal flows of solution S1 which are separately transferred into two mixing volumes where reagent solution S2 is added. The liquids are pumped through two teflon tubings which work as liquid core waveguides (LCW). Light from white light LEDs is coupled into the LCWs and the absorption spectrum of each channel is monitored by a spectrometer.

Title Page

Abstract

Introduction

Conclusions

References

Tables

Figures

◀

▶

◀

▶

Back

Close

Full Screen / Esc

Printer-friendly Version

Interactive Discussion

Development and application of a new mobile LOPAP instrument

R. Häseler et al.

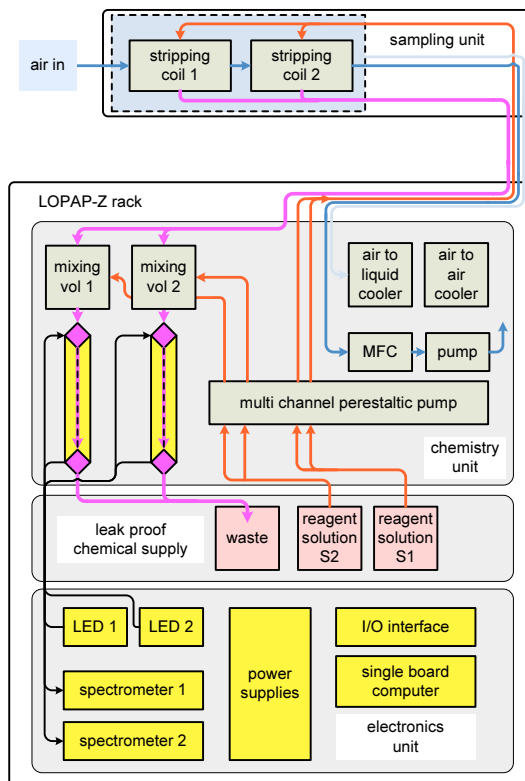

Fig. 2. Setup of the LOPAP-Z: the rack consists of 3 separate, enclosed units. Only in the upper two (chemistry and supply) wet chemicals and gases are processed. The lower, electronic unit cannot be exposed to chemicals. Colors and components are identical to Fig. 1.

Title Page

Abstract

Introduction

Conclusions

References

Tables

Figures

◀

▶

◀

▶

Back

Close

Full Screen / Esc

Printer-friendly Version

Interactive Discussion

Development and application of a new mobile LOPAP instrument

R. Häseler et al.

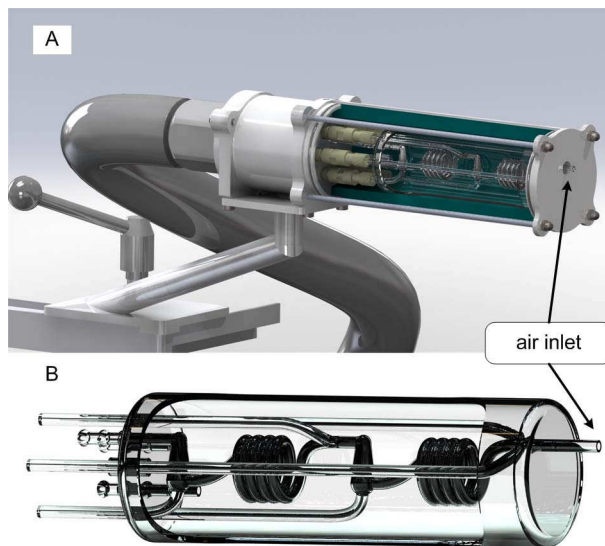

Fig. 3. New ruggedized sampling unit. A: cut away view of entire sampling unit. B: glass cylinder with stripping coils.

[Title Page](#)[Abstract](#)[Introduction](#)[Conclusions](#)[References](#)[Tables](#)[Figures](#)[I◀](#)[▶I](#)[◀](#)[▶](#)[Back](#)[Close](#)[Full Screen / Esc](#)[Printer-friendly Version](#)[Interactive Discussion](#)

Development and application of a new mobile LOPAP instrument

R. Häseler et al.

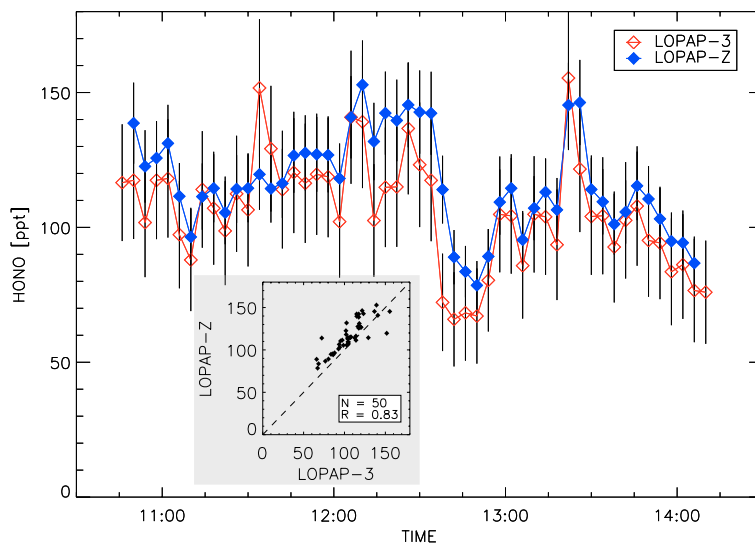

Fig. 4. Laboratory intercomparison of a LOPAP-3 instrument and the new LOPAP-Z instrument. The instruments were connected to a common inlet line sampling ambient air just outside the window of the laboratory. The airflow was split via a teflon T-piece into both sampling units. The inset shows the same data as correlation.

[Title Page](#)[Abstract](#)[Introduction](#)[Conclusions](#)[References](#)[Tables](#)[Figures](#)[⏪](#)[⏩](#)[◀](#)[▶](#)[Back](#)[Close](#)[Full Screen / Esc](#)[Printer-friendly Version](#)[Interactive Discussion](#)

Development and application of a new mobile LOPAP instrument

R. Häseler et al.



Fig. 5. Upper: Outside view of the Zeppelin NT airship during take-off. The arrow in the enlarged detail view denotes the location of the LOPAP-Z inlet. Lower: setup of the LOPAP-Z instrument aboard the Zeppelin NT airship during flight. The sampling unit sticks out of the window in the front door of the gondola, the inlet is approximately 20 cm from the surface of the gondola. The rack is mounted to the floor replacing one passenger seat.

Title Page

Abstract

Introduction

Conclusions

References

Tables

Figures

◀

▶

◀

▶

Back

Close

Full Screen / Esc

Printer-friendly Version

Interactive Discussion

**Development and
application of a new
mobile LOPAP
instrument**

R. Häseler et al.

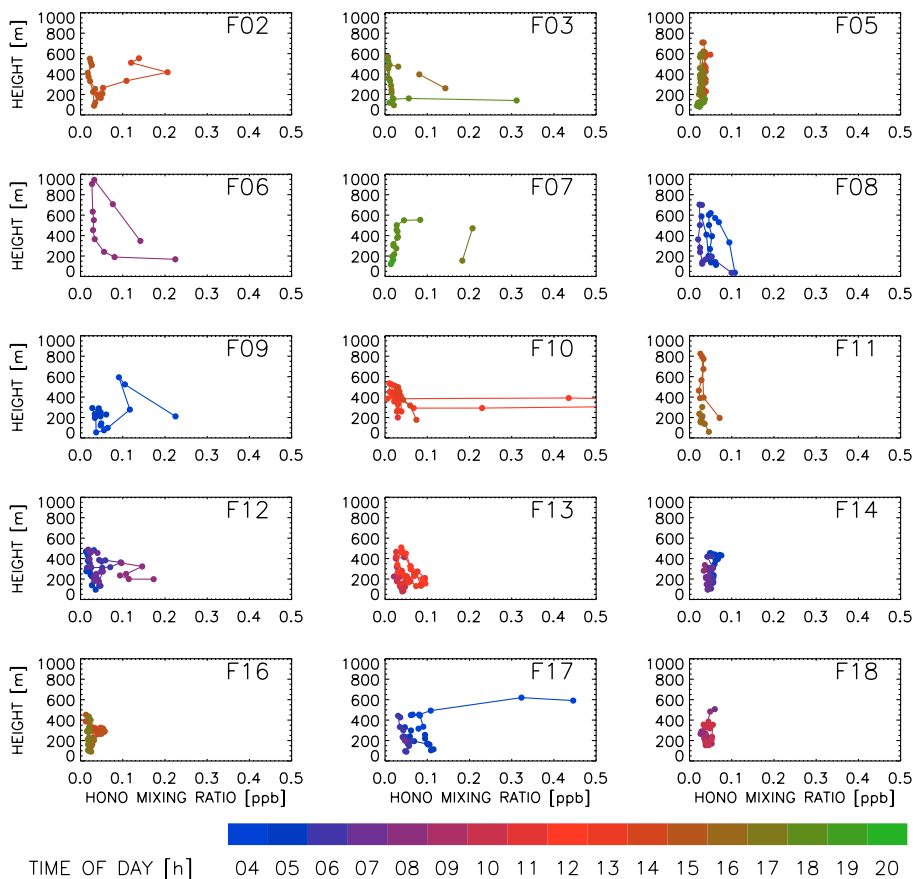

Fig. 6. Single altitude profiles of all measured HONO data during the ZEPTEr-1 campaign, July 2007. The color code refers to the daytime, for flight numbers and locations see Table 1.

[Title Page](#)[Abstract](#)[Introduction](#)[Conclusions](#)[References](#)[Tables](#)[Figures](#)[◀](#)[▶](#)[◀](#)[▶](#)[Back](#)[Close](#)[Full Screen / Esc](#)[Printer-friendly Version](#)[Interactive Discussion](#)

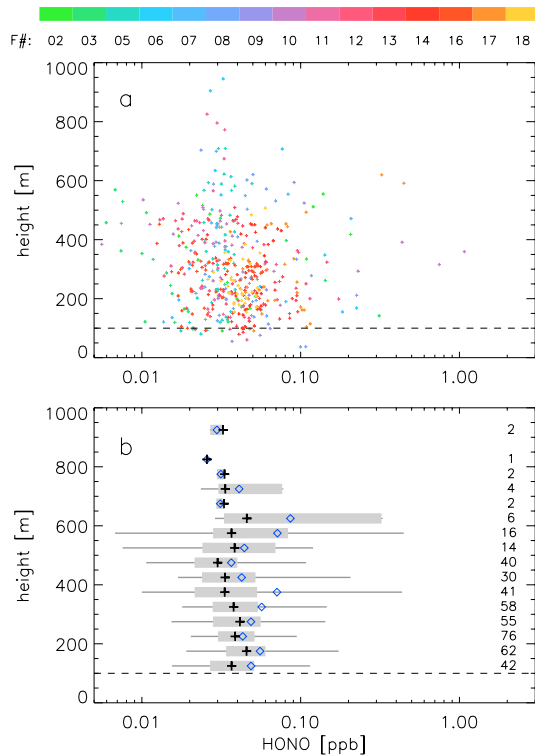

Fig. 7. Altitude profile of all measured HONO data during the ZEPTEP-1 campaign, July 2007. (a): all single data points versus height (above ground). The color code represents the flight number given in Table 1. (b): box-whisker diagram of the data grouped in 50 m intervals. The numbers indicate the number of original data points in this group. The + is the median, boxes represent 50%, the whiskers 90% of the data. The blue diamond is the average.

Development and application of a new mobile LOPAP instrument

R. Häseler et al.

Title Page

Abstract

Introduction

Conclusions

References

Tables

Figures

◀

▶

◀

▶

Back

Close

Full Screen / Esc

Printer-friendly Version

Interactive Discussion

Development and application of a new mobile LOPAP instrument

R. Häseler et al.

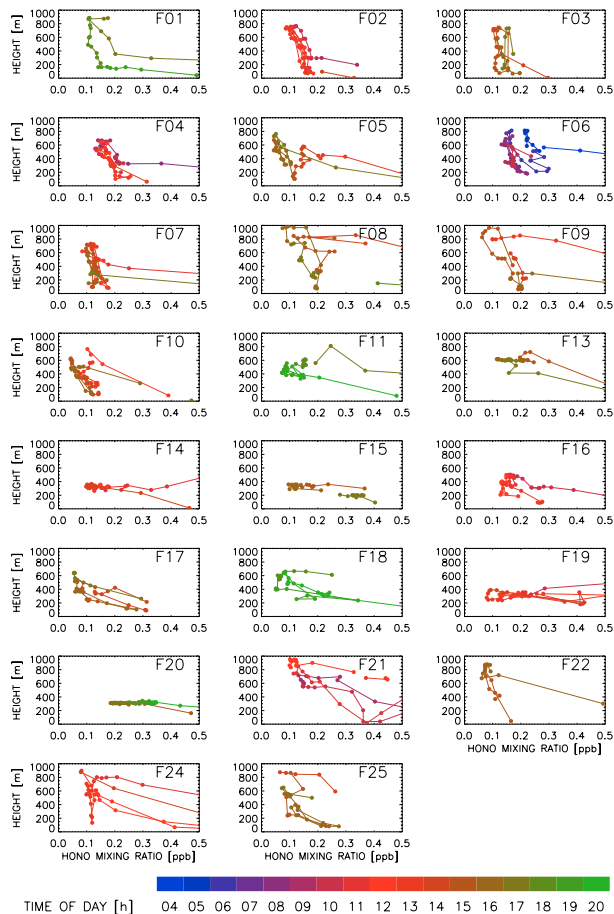

Fig. 8. Single altitude profiles of all measured HONO data during the ZEPTEr-2 campaign, July 2008. The color code refers to the daytime, for flight numbers and locations see Table 2.

[Title Page](#)[Abstract](#)[Introduction](#)[Conclusions](#)[References](#)[Tables](#)[Figures](#)[◀](#)[▶](#)[◀](#)[▶](#)[Back](#)[Close](#)[Full Screen / Esc](#)[Printer-friendly Version](#)[Interactive Discussion](#)

**Development and
application of a new
mobile LOPAP
instrument**

R. Häseler et al.

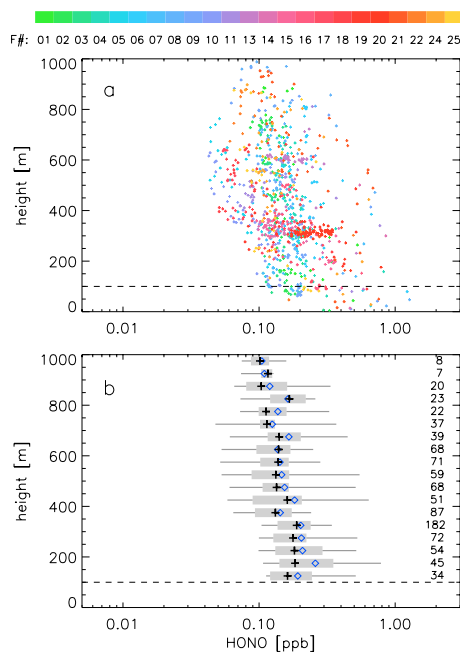

Fig. 9. Altitude profile of all measured HONO data during the ZEPTEr-2 campaign, 2008. (a): all single data points versus height (above ground). The color code represents the flight number given in Table 2. (b): box-whisker diagram of the data grouped in 50 m intervals. The numbers indicate the number of original data points in this group. The + is the median, the boxes present 50% of the data, the whiskers 5% and 95% percentiles. The blue diamond is the average.

[Title Page](#)[Abstract](#)[Introduction](#)[Conclusions](#)[References](#)[Tables](#)[Figures](#)[◀](#)[▶](#)[◀](#)[▶](#)[Back](#)[Close](#)[Full Screen / Esc](#)[Printer-friendly Version](#)[Interactive Discussion](#)

**Development and
application of a new
mobile LOPAP
instrument**

R. Häseler et al.

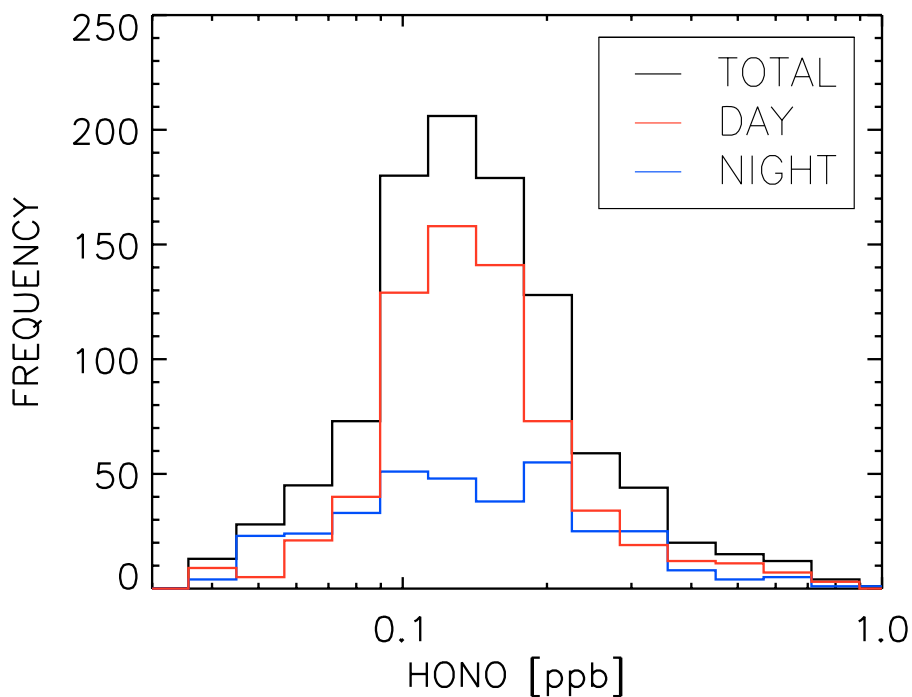

Fig. 10. Frequency distribution of HONO measurements of all flights in 2008 (Zepter-2) separated by day (SZA < 90°) and night.

[Title Page](#)[Abstract](#)[Introduction](#)[Conclusions](#)[References](#)[Tables](#)[Figures](#)[◀](#)[▶](#)[◀](#)[▶](#)[Back](#)[Close](#)[Full Screen / Esc](#)[Printer-friendly Version](#)[Interactive Discussion](#)