



KERNFORSCHUNGSANLAGE JÜLICH GmbH

Institut für Plasmaphysik
Association EURATOM - KFA

**A Constant Heat Flux Plasma Limiter
for TEXTOR**

by

P. Mioduszewski

Jül - 1681
Oktober 1980
ISSN 0366-0885

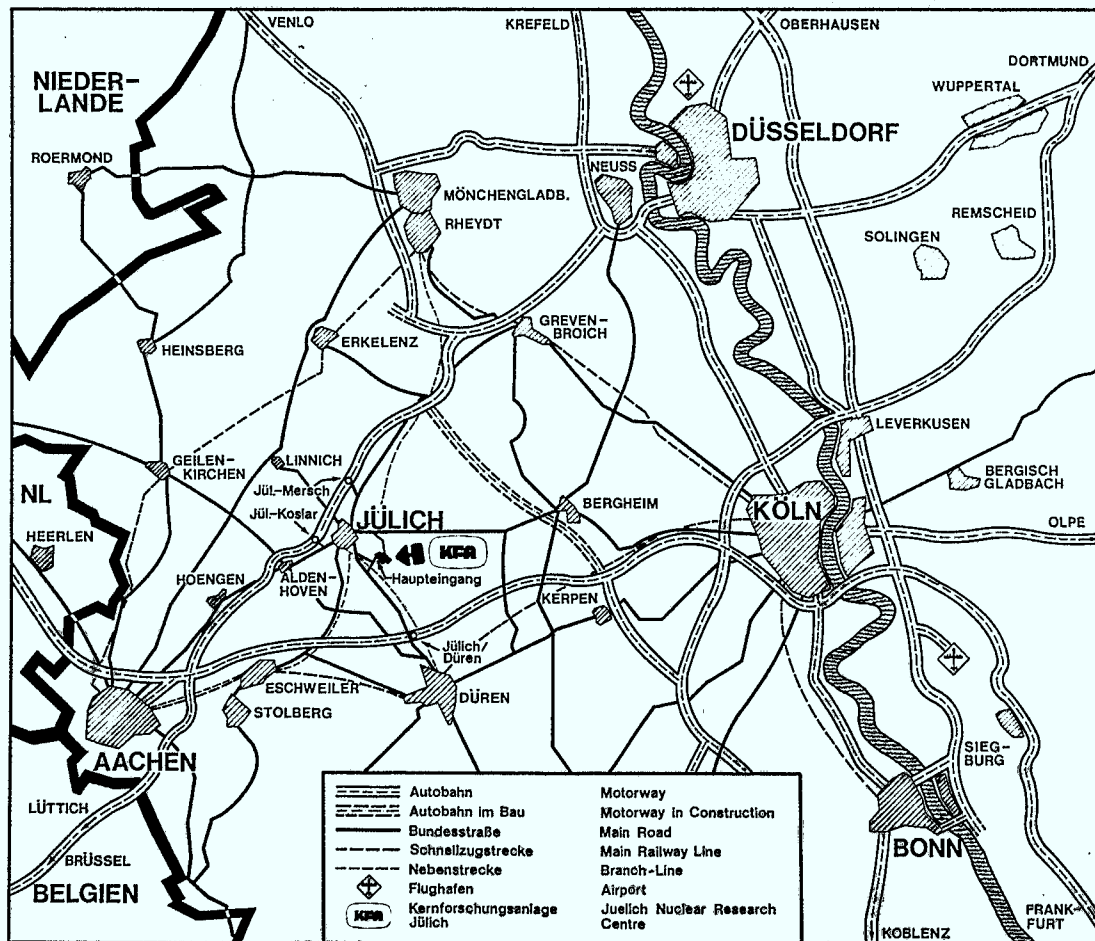

Als Manuskript gedruckt

Berichte der Kernforschungsanlage Jülich - Nr. 1681

Institut für Plasmaphysik Jülich - 1681

Zu beziehen durch: ZENTRALBIBLIOTHEK der Kernforschungsanlage Jülich GmbH

Postfach 1913 · D-5170 Jülich 1 (Bundesrepublik Deutschland)

Telefon: (02461) 61-0 · Telex: 833556 kfa d

A Constant Heat Flux Plasma Limiter for TEXTOR

by

P. Mioduszewski

1. INTRODUCTION

In future large tokamak machines heat removal from the plasma is going to play an important role. In TEXTOR /1/ the total plasma power is expected to be in the range of 0.5 - 2.5 MW. Typical fractions of about 50% of this total power have to be removed from the plasma by limiters. The power flux from the limiter scrape-off layer to the limiter surface decays rapidly with distance into the scrape-off layer resulting in a highly space-dependent heat load on the limiter. Therefore, limiters are shaped in a way to smooth off the heat load, and the ideal limiter shape should produce a constant heat flux over the whole limiter surface. The ideally shaped limiter offers a better chance to handle the high heat loads with the preferred materials like stainless steel (or inconel 625 as in the case of TEXTOR). In addition, a constant heat flux to the limiter surface facilitates limiter diagnostic observations. If, e.g. the limiter surface temperature is measured with infrared techniques, the application of appropriate heat conduction formalisms yields the corresponding heat fluxes. The procedure becomes rather simple for constant heat flux because one-dimensional heat conduction equations can be applied. At present, the main problem is the lack of knowledge on the scrape-off layer characteristics.

2. PLASMA-LIMITER INTERACTION MODEL

The interaction between plasma and limiter is not well understood up to date and is increasingly a matter of investigation. The current understanding of heat removal from the plasma by solid material limiters shall be outlined briefly: From the hot plasma core the

thermal energy is transported radially across the magnetic field into the edge plasma from where it can be removed by

- a) radiation due to impurities
- b) charge-exchange neutrals (cx)
- c) transport into the limiter scrape-off layer.

Within the limiter scrape-off layer the energy is transported via heat conduction and convection parallel to the magnetic field lines to the limiter surfaces where it is partially absorbed and partially reflected. According to this model the limiter takes the heat flux on the surfaces perpendicular to the magnetic field. With a given total energy flux the flux density to the limiter surface is a function of the scrape-off layer thickness δ and the shape of the limiter.

Early studies of the scrape-off layer /2/ yield a thickness δ of

$$\delta = \sqrt{D_{\perp} \cdot L / v_D} \quad (1)$$

with D_{\perp} , L , and v_D being the diffusion coefficient for perpendicular diffusion, the half-length of a magnetic field line and the plasma drift velocity in the scrape-off layer respectively. For the cross-field diffusion coefficient D Bohm-type diffusion /3/ is assumed with

$$D_B = \frac{1}{16} \frac{kT}{eB} .$$

In present tokamaks D_{\perp} has been deduced from experimental observations and ranges between $0,1 \cdot D_B$ and D_B /4,5/. The half-length of a magnetic field line in the scrape-off layer is πR_0 if a po-

toroidal ring limiter is employed. With a rail limiter the field line can undergo q toroidal revolutions before it hits the limiter again, q being the safety factor at the limiter position with a typical value of 3. When a bundle divertor is employed q has to be replaced by q_D the frequency of diversion which is typically in the order 10-20 /6/. The plasma drift velocity v_D has been discussed in /7/ and is assumed to be of the order of the ion sound velocity v_s . For the limiter case the drift velocity with no back-streaming is assumed to be $v_D \simeq 0.3 v_s$ which is in agreement with experimental observations /4/, /8/.

On this basis, we compute the scrape-off layer thickness for TEXTOR for the following data:

$$R_0 = 1.75 \text{ m}$$

$$kT = 50 \text{ eV}$$

$$B = 2 \text{ T}$$

$$q(a) = 3$$

$$D_B = \frac{1}{16} \frac{kT}{eB} = 1.56 \frac{\text{m}^2}{\text{s}} \quad (2)$$

$$v_D = 0.3 \sqrt{\frac{2kT}{m_i}} = 3 \cdot 10^4 \frac{\text{m}}{\text{s}} \quad (3)$$

$$L = \pi R_0 q = 16.5 \text{ m} \quad \text{rail limiter} \quad (4)$$

$$L = \pi R_0 = 5.5 \text{ m} \quad \text{ring limiter}$$

For $0.1 D_B \leq D_{\perp} \leq D_B$ the scrape-off layer thickness δ is in the

range of

$$1 \text{ cm} \leq \sigma_0 \leq 3 \text{ cm}$$

for a rail limiter, and in the range

$$0.6 \text{ cm} \leq \sigma_1 \leq 1.7 \text{ cm}$$

for a ring limiter.

Rail limiters and ring limiters can be compared with respect to the ability of heat accommodation and the requirements for plasma positioning. To see the difference in heat accommodation of the two types of limiters, we compare the respective surface areas in contact with the plasma. For the poloidal ring limiter the total contact area is $A_{\text{ring}} = 4\pi a \cdot \sigma$, assuming that the energy is dumped into a ring of $2\pi a$ from both sides. On a straight rail limiter the plasma has contact over a length of $h = 2\sqrt{2\sigma_0(a+\sigma_0)-\sigma_0^2}$ which is the chord-length between the circles of radii a and $a + \sigma_0$ respectively. Thus the total contact area is about $A_{\text{rail}} = 2h\sigma_0 = 4\sqrt{2\sigma_0 a} \cdot \sigma_0$ assuming $a \gg \sigma_0$. From Eqs. (1) and (4) we get $\sigma_0 = \sigma_1 \sqrt{q}$. This yields the ratio of rail limiter area to ring limiter area

$$R_L \approx \frac{4\sqrt{2\sigma_0 a} \sigma_1 \sqrt{q}}{4\pi a \sigma_1} = \frac{\sqrt{2q\sigma_0 a}}{\pi a} \quad (5)$$

For the TEXTOR case of $\sigma_0 = 1 \text{ cm}$, $a = 50 \text{ cm}$, $q = 3$, we get $R = 0.11$ which means that the heat dissipation on a ring limiter should be much easier compared to a rail limiter due to the larger effective contact area. The rail limiter, however, has some other

advantages. It can be manipulated easily, so that the plasma wall gap can be changed even during the discharge. In addition, the limiter blades can be changed through a vacuum lock without venting the whole torus. Furthermore, the requirements for the plasma positioning are not as severe as for the ring limiter. For ease of operation a rail limiter is preferable, provided that the given heat flux can be accommodated. As a compromise, and for the case that higher heat fluxes have to be accommodated, a curved rail limiter with curve radius a and curve length $R < 2\pi a/q$ could be considered. In particular the curved limiter can be approximated by e.g. 3 single rail limiters which can be easily positioned.

The total thermal plasma power in TEXTOR is assumed to be in the range between 500 kW (ohmic heating) and 2.6 MW (maximum neutral beam injection). Presumed that the limiter has to take about 50% of the total heating power, the power P_L to be removed by the limiter is in the range $0.25 \text{ MW} \leq P_L \leq 1.3 \text{ MW}$. To dissipate this power, especially with the rail limiter, the limiter blade has to be shaped in a way as to spread the heat flux over a sufficient large area.

3. LIMITER CONTOUR FOR CONSTANT ENERGY FLUX DENSITY

The energy flux density in the limiter scrape-off zone is assumed to be an exponential function of the distance into the scrape-off layer:

$$\dot{q}(\xi) = q_0 e^{-\frac{\xi-a}{\delta}} = q_0 e^{-\frac{x}{\delta}} \quad (6)$$

where ξ is the distance into the scrape-off layer measured from the plasma axis, a the minor plasma radius and δ the e-folding length. The definition of these quantities is illustrated in Fig.1. To avoid peak heat loads at the limiter edge we attempt to optimize the limiter surface. As proposed by J.A. Schmidt /9/ we can shape the limiter in such a way that, for a given scrape-off layer thickness δ , the energy flux density is a constant over the whole limiter surface. To find the corresponding contour $y(x)$ according to the coordinate system in Fig.1 we require that the projected power density be a constant:

$$q_0 e^{-\frac{x}{\delta}} \cdot \cos \varphi = q_0 c = \text{const.} \quad (7)$$

From Fig. 1b we find $\cos \varphi = dx/ds = dx/\sqrt{dx^2+dy^2}$ and

$$\cos \varphi = \frac{1}{\sqrt{1+(\frac{dy}{dx})^2}} = \frac{1}{\sqrt{1+y'^2}} \quad (8)$$

which yields with Eq.7 the differential equation:

$$y' = \frac{1}{c} \sqrt{e^{-2x/\delta} - c^2} \quad (9)$$

This differential equation can be solved straight forward and yields the solution for the limiter contour

$$y(x) = -\frac{\delta}{c} \left(\sqrt{e^{-2x/\delta} - c^2} - c \cdot \operatorname{arc\,tg} \frac{1}{c} \sqrt{e^{-2x/\delta} - c^2} \right) + \frac{\delta}{c} \left(\sqrt{1 - c^2} - c \cdot \operatorname{arc\,tg} \frac{1}{c} \sqrt{1 - c^2} \right). \quad (10)$$

For all $x \geq 0$ the square root must be real and therefore $c \leq 1$ and $e^{-2x/\delta} - c^2 \geq 0$. From these conditions we find that Eq.(10) is valid for

$$0 \leq x \leq -\frac{\delta}{2} \ln c^2. \quad (11)$$

Physically this means that condition (7) can be satisfied only up to a maximum $x_{\max} = -(\delta/2) \cdot \ln c^2$ because for this x_{\max} the projection angle φ gets zero and $\cos \varphi = 1$, so that the effective surface area is no longer enlarged by oblique incidence whereas the exponential still decays for increasing x . Typically we get $c = 0.1$, as we will see later, which gives $e^{-x_{\max}/\delta} = 0.1$. Thus, 90% of the total power dumped into the limiter can be accommodated on the optimized part of the limiter blade.

To find the actual contour of the limiter as given by Eq.(10) we have to work out the constant c . The quantity $q_0 c$ is the constant energy flux density and has to be chosen smaller or equal to the allowable specific surface load p_0 which depends on the thermal properties of the material and the pulse length.

We choose the appropriate specific surface load $q_0 c \equiv p_0$ and calculate c from the required surface area A_L to take the total limiter power $P_L = p_0 \cdot A_L$. For this purpose we have to compute c . The limiter surface area is the product of the total poloidal arc length R (cf. Fig. 1a) and twice the length of the shaped contour as given by Eq.(10)

$$A_L = R \cdot 2 S.$$

where $R = 2a \int_0^{\theta_0} d\theta$ and $S = \int_0^{x_{max}} ds$.

To compute the curve length S we replace $\cos \varphi$ in Eq.(7) by $\cos \varphi = dx/ds$ to yield

$$e^{-\frac{x}{\delta}} dx = c \cdot ds$$

and

$$S = \frac{1}{c} \int_0^{x_{max}} e^{-\frac{x}{\delta}} dx = -\frac{\delta}{c} e^{-\frac{x}{\delta}} \Big|_0^{x_{max}}. \quad (12)$$

With $x_{max} = -\frac{\delta}{2} \ln c^2$ we get finally the curve length as a function of c and δ :

$$S = -\frac{\delta}{c} (c-1) = \delta \left(\frac{1}{c} - 1 \right). \quad (13)$$

This gives the limiter surface area as a function of the parameter c :

$$A_L = 2a \theta_0 \cdot 2\delta \left(\frac{1}{c} - 1 \right). \quad (14)$$

Since A_L must also satisfy the condition $A_L = P_L/p_0$ we get

$$2a \theta_0 \cdot 2\delta \left(\frac{1}{c} - 1 \right) = P_L/p_0. \quad (15)$$

Here $P_L = P_0 \cdot f$ is the power to the limiter and f is a certain fraction of the total plasma power P_0 , typically $f = 0.2 - 0.8$. In addition, we have to keep in mind that the shaped limiter extends only up to a radial distance x_{max} into the scrape-off layer and

beyond this point there is still some power $P_L e^{-x_{max}/\delta}$ which may be dumped into the non-shaped part of the limiter blade and must not be included in the computation of c . Therefore, the power flowing into the shaped part of the limiter is $P_{LS} = P_L(1 - e^{-x_{max}/\delta}) = P_L(1 - c)$. For the accurate determination of c the power to the limiter P_L in Eq.(15) has to be replaced by $P_{LS} = P_L(1 - c)$ which yields a quadratic equation for c . For the accuracy needed here we determine c from Eq.(15):

$$c = \frac{1}{\frac{P_0 f}{4 p_0 a \theta_0 \delta} + 1} \quad (16)$$

As an example for TEXTOR we assume $P_0 = 450$ kW, $f = 0.8$, $a = 50$ cm, $\theta_0 = 0.3$ (which corresponds to $R = 30$ cm). For the allowable surface heat load we assume ~ 5 MW/m² which is typical for stainless steel and pulse lengths of 1 s. The corresponding values of c are given in table 1.

δ [cm]	c
0.5	0.040
1	0.0769
1.5	0.111
2	0.1428
2.5	0.172
3	0.20

Table 1: Parameter c as function of scrape-off layer for $p_0 = 5$ MW/m²

The limiter contours with these parameters as computed by means of Eq.(10) are shown in Fig.2. The limiter surface area is determined with Eq.(14) and gives for this case $A_L = 720 \text{ cm}^2$.

The main problem with the shaped limiter is the fact that the scrape-off layer thickness is not well known in advance. If the limiter contour is designed for a scrape-off layer thickness δ_1 , but the actual scrape-off layer thickness is $\delta_2 \neq \delta_1$, the surface heat load is not constant any more as assumed in Eq.(7). The projected energy flux density changes now as a function of x which can be computed by means of

$$e^{-\frac{x}{\delta_2}} \cdot \cos \varphi = f(x), \quad (17)$$

where $\cos \varphi$ is given by Eqs.(8) and (9) setting $\delta = \delta_1$. This yields the variation of the energy flux density over the limiter surface

$$f(x) = c_1 e^{-x \left(\frac{\delta_1 - \delta_2}{\delta_1 \cdot \delta_2} \right)}, \quad (18)$$

where c_1 corresponds to δ_1 , according to table 1. For $\delta_1 = \delta_2$ the limiter contour fits the actual e-folding length in the scrape-off layer. For $\delta_1 > \delta_2$ the projected limiter surface area decreases slower with increasing x than the actual heat flux density, therefore, the heat flux density on the limiter contour decreases with x . Finally, for $\delta_1 < \delta_2$ the projected limiter surface decreases more rapidly than the heat flux and thus the energy flux density on the limiter increases with x .

As a compromise, especially for the initial phase of operation, a limiter with variable shape is suggested. This is illustrated in Fig.3 and might be explained by an example. If we assume that the scrape-off layer thickness δ is most probably in the range $1 \text{ cm} \leq \delta \leq 2 \text{ cm}$, we design a limiter with a contour corresponding to $\delta = 1.5 \text{ cm}$ and make the two wings movable around the axis through $x = 0$ (perpendicular to the drawing plane in Fig.3). As can be seen, the deviation from ideal geometry is only small within the given range. Once the e-folding length of the power flux in the scrape-off layer is known, a limiter blade with the proper contour can be designed.

By technical reasons it might be necessary to abandon the poloidal shaping in this case. The slope at $x = 0$ can be deduced from Eq.(9); for $\delta = 1 \text{ cm}$ we get $\alpha = 85.6^\circ$ and for $\delta = 2 \text{ cm}$ we get $\alpha = 81.8^\circ$.

4. THERMAL RESPONSE OF THE LIMITER

If the limiter is optimized according to the considerations of the previous chapter, the energy flux density is constant over the whole limiter surface. This has the advantage that the one-dimensional heat conduction formalism can be employed.

As an example we study a limiter with blades of inconel 625, 1 cm wall thickness and shaped as outlined above. The material properties are temperature dependent, but for rough estimates average values which correspond to about 500° C are given in table 2.

density	ρ	= 8.4 · 10 ³ kg/m ³
melting temperature	T_M	= 1400° C
specific heat	C	= 0.6 · 10 ³ J/kgK
thermal conductivity	K	= 22 W/mK
thermal diffusivity	α	= 4.5 · 10 ⁻⁶ m ² /s
maximum stress	σ_m	= 680 MPa
Young's modulus	E	= 17 · 10 ⁴ MPa
coeff. of thermal expansion	α	= 17 · 10 ⁻⁶ K ⁻¹
Poisson's number	ν	= 0.3
characteristic length (for t = 1 s)	$\sqrt{4\alpha t}$	= 4.2 · 10 ⁻³ m

Table 2: Materials properties of inconel 625

For more accurate computations we make use of a plot of the parameter $(1/K) \sqrt{4\alpha/\pi t}$ as a function of temperature given in /10/.

Under the assumption that the wall thickness is large compared to the thermal penetration depth of the surface heat pulse the limiter blade temperature rise due to a heat pulse of duration t

and energy flux density p_0 can be described by /11/

$$\Delta T(x, t) = \frac{p_0}{K} \left(\sqrt{\frac{4\alpha t}{\pi}} e^{-x^2/4\alpha t} - x \operatorname{erfc} \frac{x}{\sqrt{4\alpha t}} \right) . \quad (19)$$

For $x = 0$ we get the surface temperature rise

$$\Delta T(0, t) = \frac{p_0}{K} \sqrt{\frac{4\alpha t}{\pi}} . \quad (20)$$

Substituting $u^2 = x^2/4\alpha t$ in Eq.(19) and putting $(1/\sqrt{\pi}) e^{-u^2} - u \operatorname{erfc}(u) \equiv \operatorname{ierfc}(u)$ yields the relation

$$\Delta T(x, t) = \Delta T(0, t) \sqrt{\pi} \cdot \operatorname{ierfc}(u) . \quad (21)$$

The function $\sqrt{\pi} \cdot \operatorname{ierfc}(u)$ is tabulated and is plotted in Fig.4. By means of this curve the penetration depth of the heat pulse can be estimated easily. For instance, a temperature rise of 10% of the surface temperature rise gives $u = 0.95$, i.e. $x = u \cdot \sqrt{4\alpha t} = 4$ mm. From this finding we can conclude backwards that a wall thickness of 1 cm is large enough, in our case, to employ the results of heat conduction in a semi-infinite body.

By means of Eq.(20) we can give estimates for the maximum allowable heat flux due to surface melting and surface cracking. For the initial target temperature T_0 and the melting temperature T_M we find the maximum allowable heat flux:

$$P_{\max}^M = K \sqrt{\frac{\pi}{4\alpha t}} (T_M - T_0) . \quad (22)$$

With $t = 1$ s and the material constants of table 2 we get $p_{\max}^M = 9.2 \cdot 10^3 \Delta T$. The initial temperature of the TEXTOR limiter can be as high as 600° C which yields $p_{\max}^M = 7.4$ MW/m². For $T_0 = 600^\circ$ C and the reference case of $p_0 = 5$ MW/m² used in chapter 3 the surface temperature gets up to $T_s = 1138^\circ$ C. These estimates hold for average energy flux densities p_0 . It is obvious that transients much higher than p_0 can be allowed. From Eq.(22) we see that e.g. $10 \cdot p_0$ can be tolerated for 10 ms to give the same surface temperature.

The thermal stresses in the limiter material for the non-stationary case are given by

$$\sigma = \frac{\alpha E}{(1-\nu)} \Delta T . \quad (23)$$

Combining this with Eq.(20) we get the allowable heat flux for maximum stress:

$$p_{\max}^S = \frac{\sigma_{\max}(1-\nu)K}{\alpha E} \sqrt{\frac{\pi}{4\alpha e t}} . \quad (24)$$

With the materials properties of table 2 and $t = 1$ s we get $p_{\max}^S = 3.5$ MW/m² which is considerably lower than the flux for surface melting.

Compared to these figures, experimental results reveal that for all metals surface melting is the limiting process whereas ceramics fail by surface fracture under high heat loads /12/. This suggests that at high temperatures the thermal stresses in metals are probably removed by plastic flow. For type 304 stainless steel the

limiting melting was found to be 25 MW/m^2 for $t = 0.5$ and $T_0 = 200^\circ \text{ C}$ /12/. This corresponds to 17.6 MW/m^2 for 1 s pulse as compared to 11 MW/m^2 computed by means of Eq.(22). Part of this discrepancy might be explained by the temperature dependence of the materials properties.

After heat equilibration the average temperature rise of a limiter blade of thickness d , surface area A_L , absorbed power P_L and pulse duration t_0 is

$$\Delta T_{av} = \frac{1}{\rho A_L d C} \int_0^{t_0} P_L dt. \quad (25)$$

For our reference case $P_L/A_L = 5 \text{ MW/m}^2$ and $d = 1 \text{ cm}$ Eq. (25) yields $\Delta T_{av} = 100 \text{ K}$. Thus the limiter cooling system must cool the limiter down by 100 K between shots.

The limiter design described here is fairly conservative with respect to the heat load. We have chosen a specific heat load of 5 MW/m^2 whereas calculations as well as experiments suggest that 10 MW/m^2 might be feasible. In addition, we have designed the limiter for 80% of the total plasma power whereas 40% is more likely according to present experimental results. Therefore, the inconel limiter described here might be employed for plasma powers up to 1.8 MW, presumed that the limiter shape is ideally matched to the scrape-off layer. For more secure operation a graphite limiter would be preferable. According to experimental results /12/ graphite can take up to 60 MW/m^2 of surface heat load for pulse of 1 s.

5. CONCLUSIONS

We have attempted to design a poloidal plasma limiter with locally constant surface load. The shape of this limiter is a function of the scrape-off layer characteristics. Assuming an exponential decay of the power flux in the scrape-off layer the specific shape is a function of the e-folding length δ . Since δ is not likely to be known accurately at the beginning of operations one has to find the correct shape iteratively. For this procedure it would be helpful to operate the limiter through a vacuum lock in order to be able to exchange the limiter blade easily. In addition, one can try to employ a limiter with 'in situ' variable shape as described in chapter 3.

For the correctly shaped limiter the surface heat load does not seem to cause a problem. For the ohmically heated TEXTOR an inconel limiter with 5 MW/m^2 seems appropriate whereas high auxiliary heating might call for a graphite limiter for secure operation.

REFERENCES

- /1/ Report on the Planning of TEXTOR
Nov.15, (1975)
- /2/ Yoshikawa, S., Harries, W.L., Sinclair, R.M.
Phys. Fluids 6 (1963) 1506
- /3/ D. Bohm
in "The Characteristics of Electrical Discharges in Magnetic
Fields", ed. by A. Guthrie and R.K. Wakerling, McGraw-Hill,
New York 1949, Chap.2, Ser.5
- /4/ Sengoku, S. and Ohtsuka, H.
4th Intern. Conf. on Plasma Surface Interactions,
Garmisch-Partenkirchen, April 1980, to be published in:
J. Nucl. Mat. (1980)
- /5/ Proudfoot, G. and Harbour, P.J.
4th Intern. Conf. on Plasma Surface Interactions,
Garmisch-Partenkirchen, April 1980, to be published in:
J. Nucl. Mat. (1980)
- /6/ Stott, P.E., Wilson, C.M., and Gibson, A.
Nucl. Fusion 17 (1977) 481
- /7/ Harrison, M.F.A., Harbour, P.J., Hotston, E.S., Morgan, J.G.
4th Intern. Conf. on Plasma Surface Interactions,
Garmisch-Partenkirchen, April 1980, to be published in:
J. Nucl. Mat. (1980)
- /8/ Kimura, H., Maeda, H., Ueda, N., Seki, M., Kawamura, H.,
Yamamoto, S., Nagami, M., Odajima, K., Sengoku, S.,
Shimomura, Y.
Nucl. Fusion 18 (1978) 1195
- /9/ Schmidt, J.A.
Princeton University, TFTR Physics Report No.12 (1979)
- /10/ Behrisch, R.
4th Intern. Conf. on Plasma Surface Interactions,
Garmisch-Partenkirchen, April 1980, to be published in:
J. Nucl. Mat. (1980)

- /11/ Carslaw, H.W. and Jaeger, J.C.
"Conduction of Heat in Solids", Oxford, Calderon Press (1959)
- /12/ Ulrickson, M.
J. Nucl. Mat. 85 & 86 (1979) 231

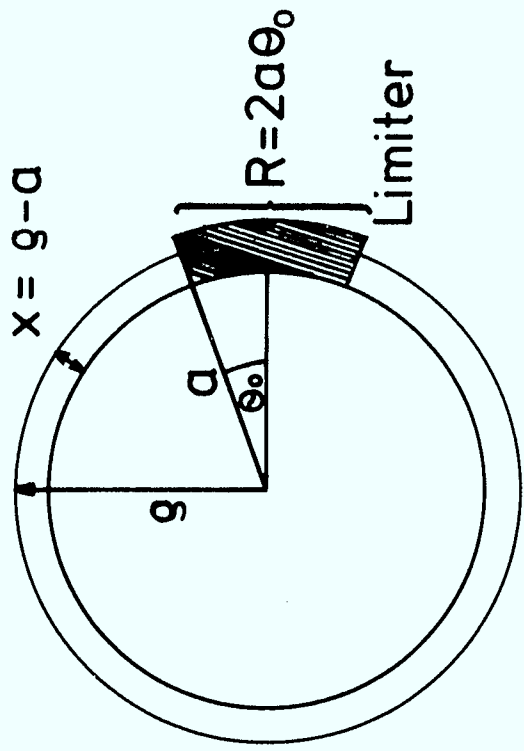

a) poloidal cross-section

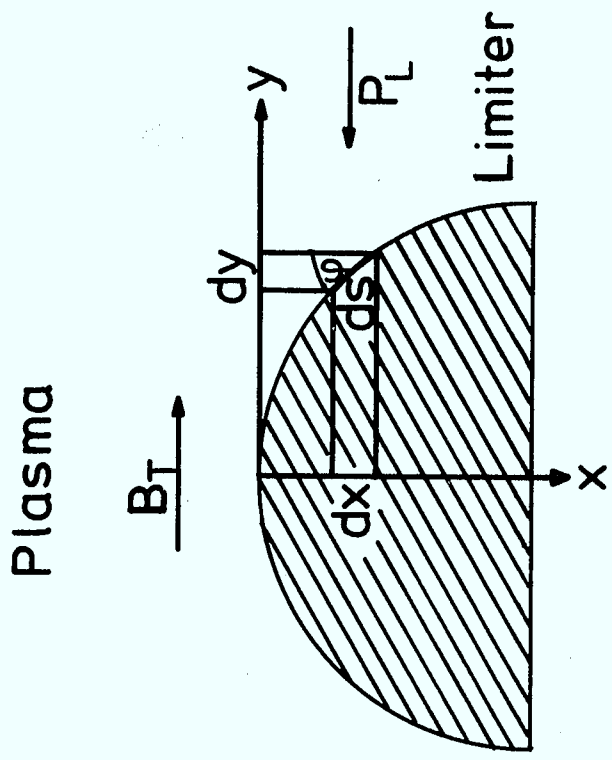

b) limiter geometry

Fig. 1 Limiter geometry and used coordinate system.

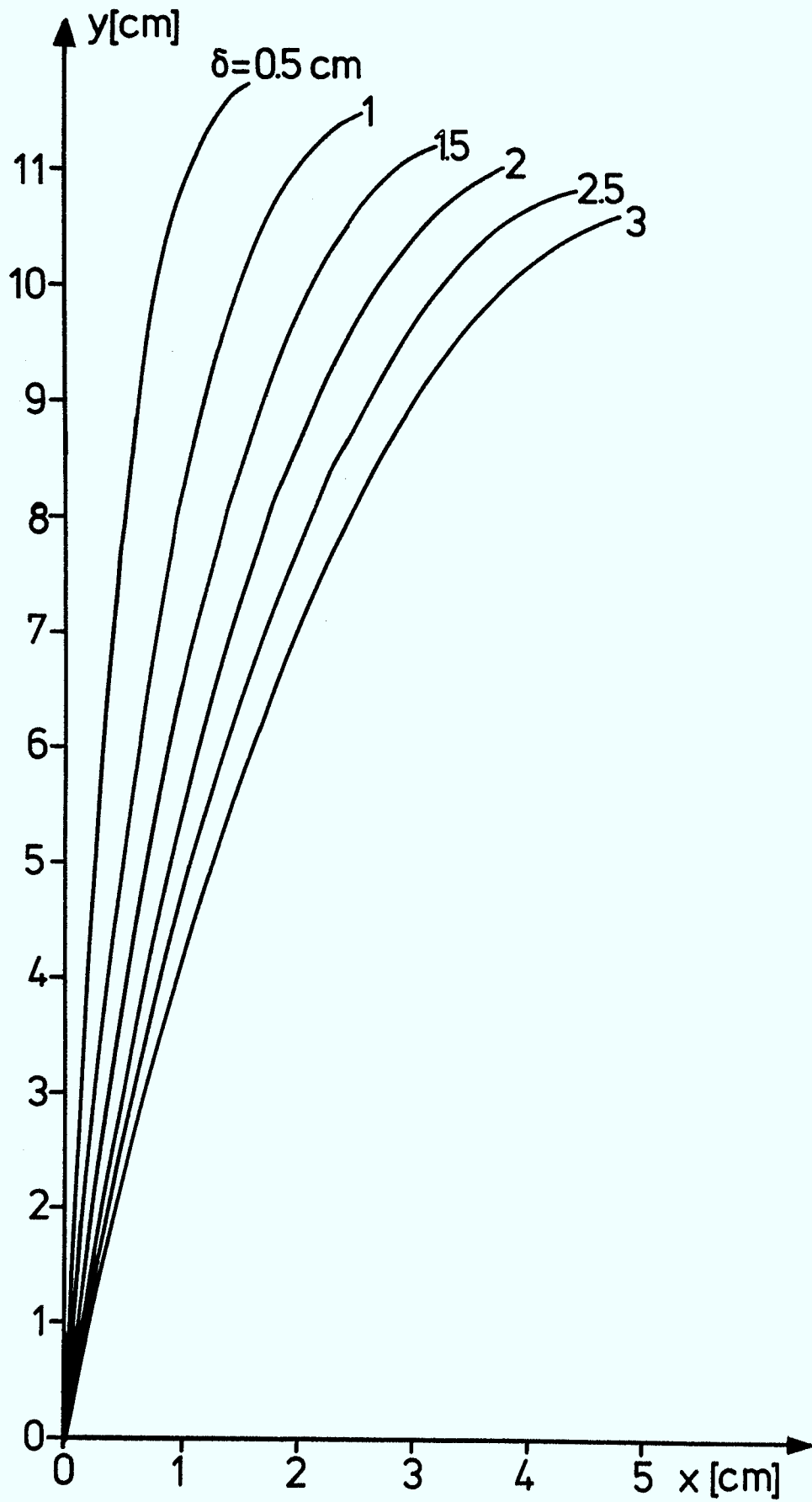

Fig. 2 Limiter shape for constant heat flux as function of scrape-off layer of thickness δ .

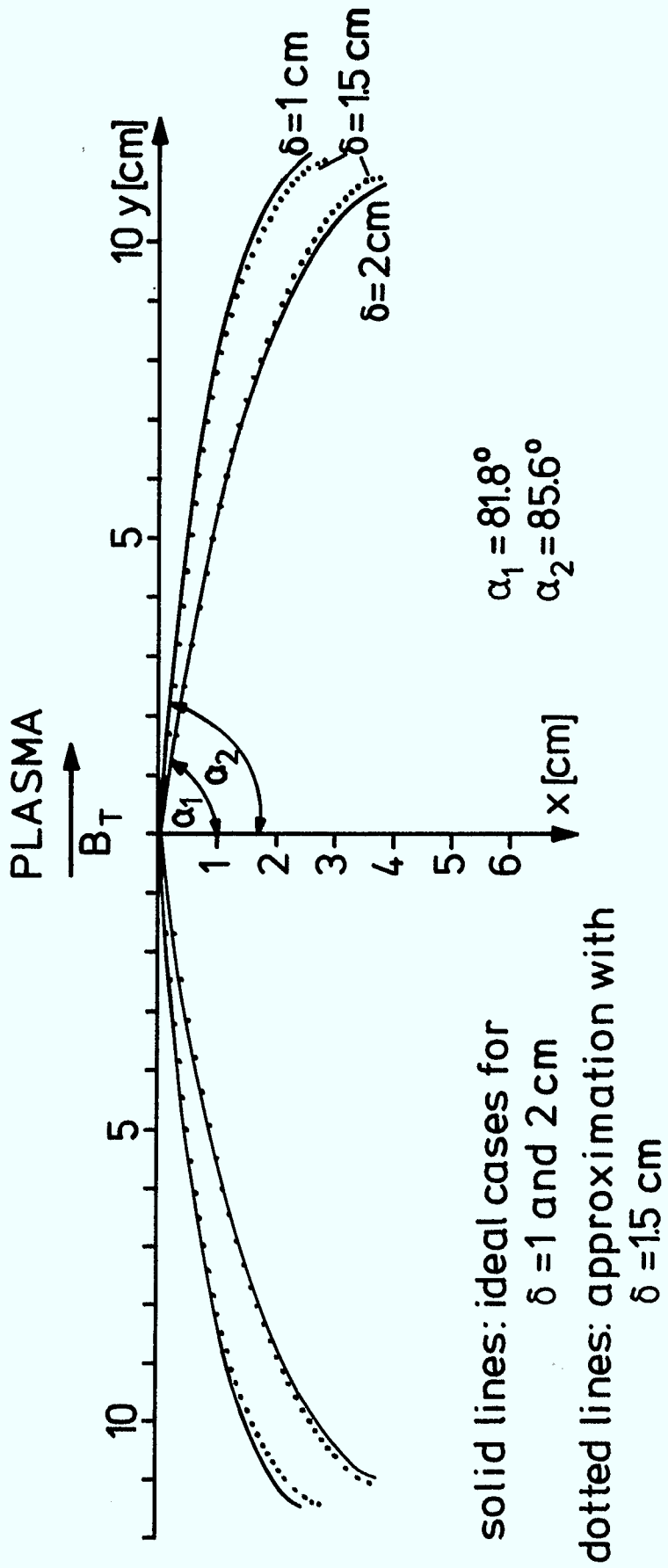

Fig. 3 Shaped limiter with the wings movable around $x = 0$.

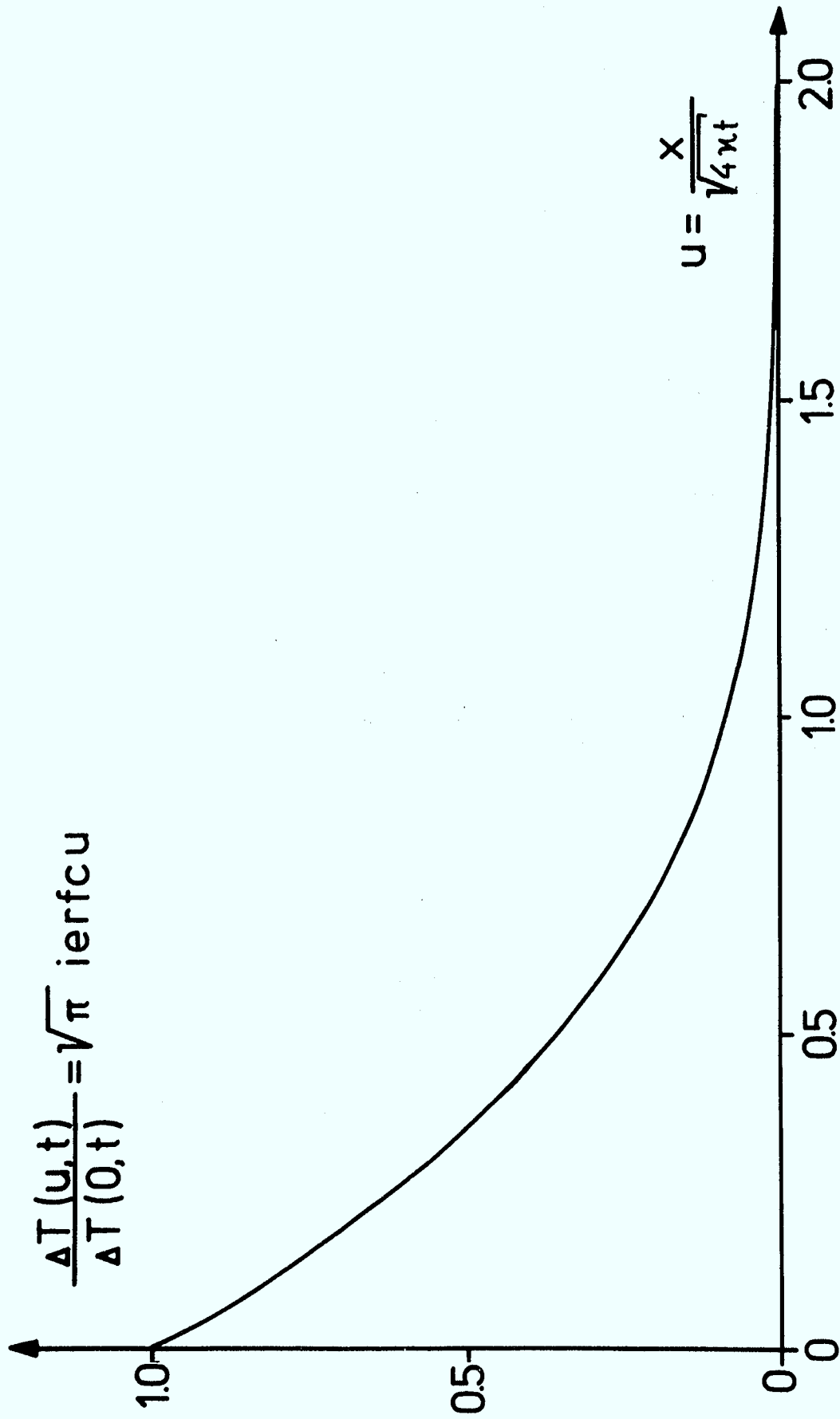

Fig. 4 Normalized penetration depth of heat pulse.